

## CHAPTER 5

# CHIMNEYS AND VENTS

### SECTION 501 (IFGC) GENERAL

**501.1 Scope.** This chapter shall govern the installation, maintenance, repair and approval of factory-built chimneys, chimney liners, vents and connectors and the utilization of masonry chimneys serving gas-fired appliances. The requirements for the installation, maintenance, repair and approval of factory-built chimneys, chimney liners, vents and connectors serving appliances burning fuels other than fuel gas shall be regulated by the *International Mechanical Code*. The construction, repair, maintenance and approval of masonry chimneys shall be regulated by the *International Building Code*.

**501.1.1 Equipment changes.** Upon the replacement or new installation of any fuel-burning appliances or equipment in existing buildings, an inspection or inspections shall be conducted to ensure that the connected vent or chimney systems comply with the following:

1. Vent or chimney systems are sized in accordance with this code.
2. Vent or chimney systems are clean, free of any obstruction or blockages, defects or deterioration and are in operable condition.

Where not inspected by the local building department, persons performing such changes or installations shall certify to the building official that the requirements of Items 1 and 2 of this section are met.

**501.2 General.** Every appliance shall discharge the products of combustion to the outdoors, except for appliances exempted by Section 501.8.

**501.3 Masonry chimneys.** Masonry chimneys shall be constructed in accordance with Section 503.5.3 and the *International Building Code*.

**501.4 Minimum size of chimney or vent.** Chimneys and vents shall be sized in accordance with Section 504.

**501.5 Abandoned inlet openings.** Abandoned inlet openings in chimneys and vents shall be closed by an approved method.

**501.6 Positive pressure.** Where an appliance equipped with a mechanical forced draft system creates a positive pressure in the venting system, the venting system shall be designed for positive pressure applications.

**501.7 Connection to fireplace.** Connection of appliances to chimney flues serving fireplaces shall be in accordance with Sections 501.7.1 through 501.7.3.

**501.7.1 Closure and access.** A noncombustible seal shall be provided below the point of connection to prevent entry of room air into the flue. Means shall be provided for access to the flue for inspection and cleaning.

**501.7.2 Connection to factory-built fireplace flue.** An appliance shall not be connected to a flue serving a factory-built fireplace unless the appliance is specifically listed

for such installation. The connection shall be made in accordance with the appliance manufacturer's installation instructions.

**501.7.3 Connection to masonry fireplace flue.** A connector shall extend from the appliance to the flue serving a masonry fireplace such that the flue gases are exhausted directly into the flue. The connector shall be accessible or removable for inspection and cleaning of both the connector and the flue. Listed direct connection devices shall be installed in accordance with their listing.

**501.8 Equipment not required to be vented.** The following appliances shall not be required to be vented.

1. Ranges.
2. Built-in domestic cooking units listed and marked for optional venting.
3. Hot plates and laundry stoves.
4. Type 1 clothes dryers (Type 1 clothes dryers shall be exhausted in accordance with the requirements of Section 614).
5. A single booster-type automatic instantaneous water heater, where designed and used solely for the sanitizing rinse requirements of a dishwashing machine, provided that the heater is installed in a commercial kitchen having a mechanical exhaust system. Where installed in this manner, the draft hood, if required, shall be in place and unaltered and the draft hood outlet shall be not less than 36 inches (914 mm) vertically and 6 inches (152 mm) horizontally from any surface other than the heater.
6. Refrigerators.
7. Counter appliances.
8. Room heaters listed for unvented use.
9. Direct-fired make-up air heaters.
10. Other equipment listed for unvented use and not provided with flue collars.
11. Specialized equipment of limited input such as laboratory burners and gas lights.

Where the appliances and equipment listed in Items 5 through 11 above are installed so that the aggregate input rating exceeds 20 British thermal units (Btu) per hour per cubic foot (207 watts per m<sup>3</sup>) of volume of the room or space in which such appliances and equipment are installed, one or more shall be provided with venting systems or other approved means for conveying the vent gases to the outdoor atmosphere so that the aggregate input rating of the remaining unvented appliances and equipment does not exceed the 20 Btu per hour per cubic foot (207 watts per m<sup>3</sup>) figure. Where the room or space in which the equipment is installed is directly connected to another room or space by a doorway, archway or other opening

of comparable size that cannot be closed, the volume of such adjacent room or space shall be permitted to be included in the calculations.

**501.9 Chimney entrance.** Connectors shall connect to a masonry chimney flue at a point not less than 12 inches (305 mm) above the lowest portion of the interior of the chimney flue.

**501.10 Connections to exhauster.** Appliance connections to a chimney or vent equipped with a power exhauster shall be made on the inlet side of the exhauster. Joints on the positive pressure side of the exhauster shall be sealed to prevent flue-gas leakage as specified by the manufacturer's installation instructions for the exhauster.

**501.11 Masonry chimneys.** Masonry chimneys utilized to vent appliances shall be located, constructed and sized as specified in the manufacturer's installation instructions for the appliances being vented and Section 503.

**501.12 Residential and low-heat appliances flue lining systems.** Flue lining systems for use with residential-type and low-heat appliances shall be limited to the following:

1. Clay flue lining complying with the requirements of ASTM C 315 or equivalent. Clay flue lining shall be installed in accordance with the *International Building Code*.
2. Listed chimney lining systems complying with UL 1777.
3. Other approved materials that will resist, without cracking, softening or corrosion, flue gases and condensate at temperatures up to 1,800°F (982°C).

**501.13 Category I appliance flue lining systems.** Flue lining systems for use with Category I appliances shall be limited to the following:

1. Flue lining systems complying with Section 501.12.
2. Chimney lining systems listed and labeled for use with gas appliances with draft hoods and other Category I gas appliances listed and labeled for use with Type B vents.

**501.14 Category II, III and IV appliance venting systems.** The design, sizing and installation of vents for Category II, III and IV appliances shall be in accordance with the appliance manufacturer's installation instructions.

**501.15 Existing chimneys and vents.** Where an appliance is permanently disconnected from an existing chimney or vent, or where an appliance is connected to an existing chimney or vent during the process of a new installation, the chimney or vent shall comply with Sections 501.15.1 through 501.15.4.

**501.15.1 Size.** The chimney or vent shall be resized as necessary to control flue gas condensation in the interior of the chimney or vent and to provide the appliance or appliances served with the required draft. For Category I appliances, the resizing shall be in accordance with Section 502.

**501.15.2 Flue passageways.** The flue gas passageway shall be free of obstructions and combustible deposits and shall be cleaned if previously used for venting a solid or liquid fuel-burning appliance or fireplace. The flue liner, chimney inner wall or vent inner wall shall be continuous and shall be free of cracks, gaps, perforations or other damage or deteri-

oration which would allow the escape of combustion products, including gases, moisture and creosote.

**501.15.3 Cleanout.** Masonry chimney flues shall be provided with a cleanout opening having a minimum height of 6 inches (152 mm). The upper edge of the opening shall be located not less than 6 inches (152 mm) below the lowest chimney inlet opening. The cleanout shall be provided with a tight-fitting, noncombustible cover.

**501.15.4 Clearances.** Chimneys and vents shall have air-space clearance to combustibles in accordance with the *International Building Code* and the chimney or vent manufacturer's installation instructions. Noncombustible firestopping or fireblocking shall be provided in accordance with the *International Building Code*.

**Exception:** Masonry chimneys equipped with a chimney lining system tested and listed for installation in chimneys in contact with combustibles in accordance with UL 1777, and installed in accordance with the manufacturer's instructions, shall not be required to have clearance between combustible materials and exterior surfaces of the masonry chimney.

## SECTION 502 (IFGC) VENTS

**502.1 General.** All vents, except as provided in Section 503.7, shall be listed and labeled. Type B and BW vents shall be tested in accordance with UL 441. Type L vents shall be tested in accordance with UL 641. Vents for Category II and III appliances shall be tested in accordance with UL 1738. Plastic vents for Category IV appliances shall not be required to be listed and labeled where such vents are as specified by the appliance manufacturer and are installed in accordance with the appliance manufacturer's installation instructions.

**502.2 Connectors required.** Connectors shall be used to connect appliances to the vertical chimney or vent, except where the chimney or vent is attached directly to the appliance. Vent connector size, material, construction and installation shall be in accordance with Section 503.

**502.3 Vent application.** The application of vents shall be in accordance with Table 503.4.

**502.4 Insulation shield.** Where vents pass through insulated assemblies, an insulation shield constructed of not less than 26 gage sheet (0.016 inch) (0.4 mm) metal shall be installed to provide clearance between the vent and the insulation material. The clearance shall not be less than the clearance to combustibles specified by the vent manufacturer's installation instructions. Where vents pass through attic space, the shield shall terminate not less than 2 inches (51 mm) above the insulation materials and shall be secured in place to prevent displacement. Insulation shields provided as part of a listed vent system shall be installed in accordance with the manufacturer's installation instructions.

**502.5 Installation.** Vent systems shall be sized, installed and terminated in accordance with the vent and appliance manufacturer's installation instructions and Section 503.

**502.6 Support of vents.** All portions of vents shall be adequately supported for the design and weight of the materials employed.

**502.7 Protection against physical damage.** In concealed locations, where a vent is installed through holes or notches in studs, joists, rafters or similar members less than 1.5 inches (38 mm) from the nearest edge of the member, the vent shall be protected by shield plates. Shield plates shall be a minimum of 1/16-inch-thick (1.6 mm) steel, shall cover the area of the vent where the member is notched or bored and shall extend a minimum of 4 inches (102 mm) above sole plates, below top plates and to each side of a stud, joist or rafter.

## SECTION 503 (IFGS) VENTING OF APPLIANCES

**503.1 General.** This section recognizes that the choice of venting materials and the methods of installation of venting systems are dependent on the operating characteristics of the appliance being vented. The operating characteristics of vented appliances can be categorized with respect to: (1) positive or negative pressure within the venting system; and (2) whether or not the appliance generates flue or vent gases that might condense in the venting system. See Section 202 for the definitions of these vented appliance categories.

**503.2 Venting systems required.** Except as permitted in Sections 503.2.1 through 503.2.4 and 501.8, all appliances shall be connected to venting systems.

**503.2.1 Ventilating hoods.** Ventilating hoods and exhaust systems shall be permitted to be used to vent appliances installed in commercial applications (see Section 503.3.4) and to vent industrial appliances, such as where the process itself requires fume disposal.

**503.2.2 Well-ventilated spaces.** Where located in a large and well-ventilated space, industrial appliances shall be permitted to be operated by discharging the flue gases directly into the space.

**503.2.3 Direct-vent appliances.** Listed direct-vent appliances shall be installed in accordance with the manufacturer's instructions and Section 503.8, Item 3.

**503.2.4 Appliances with integral vents.** Appliances incorporating integral venting means shall be considered properly vented where installed in accordance with the manufacturer's instructions and Section 503.8, Items 1 and 2.

**503.3 Design and construction.** A venting system shall be designed and constructed so as to develop a positive flow adequate to convey flue or vent gases to the outdoors.

**503.3.1 Appliance draft requirements.** A venting system shall satisfy the draft requirements of the appliance in accordance with the manufacturer's instructions.

**503.3.2 Design and construction.** Appliances required to be vented shall be connected to a venting system designed and installed in accordance with the provisions of Sections 503.4 through 503.15.

**503.3.3 Mechanical draft systems.** Mechanical draft systems shall comply with the following:

1. Mechanical draft systems shall be listed and shall be installed in accordance with the manufacturer's installation instructions for both the appliance and the mechanical draft system.
2. Appliances, except incinerators, requiring venting shall be permitted to be vented by means of mechanical draft systems of either forced or induced draft design.
3. Forced draft systems and all portions of induced draft systems under positive pressure during operation shall be designed and installed so as to prevent leakage of flue or vent gases into a building.
4. Vent connectors serving appliances vented by natural draft shall not be connected into any portion of mechanical draft systems operating under positive pressure.
5. Where a mechanical draft system is employed, provisions shall be made to prevent the flow of gas to the main burners when the draft system is not performing so as to satisfy the operating requirements of the appliance for safe performance.
6. The exit terminals of mechanical draft systems shall be not less than 7 feet (2134 mm) above grade where located adjacent to public walkways and shall be located as specified in Section 503.8, Items 1 and 2.

**503.3.4 Ventilating hoods and exhaust systems.** Ventilating hoods and exhaust systems shall be permitted to be used to vent appliances installed in commercial applications. Where automatically operated appliances are vented through a ventilating hood or exhaust system equipped with a damper or with a power means of exhaust, provisions shall be made to allow the flow of gas to the main burners only when the damper is open to a position to properly vent the appliance and when the power means of exhaust is in operation.

**503.3.5 Circulating air ducts and furnace plenums.** No portion of a venting system shall extend into or pass through any circulating air duct or furnace plenum.

**503.3.6 Above-ceiling air-handling spaces.** Where a venting system passes through an above-ceiling air-handling space or other nonducted portion of an air-handling system, the venting system shall conform to one of the following requirements:

1. The venting system shall be a listed special gas vent; other venting system serving a Category III or Category IV appliance; or other positive pressure vent, with joints sealed in accordance with the appliance or vent manufacturer's instructions.
2. The venting system shall be installed such that fittings and joints between sections are not installed in the above-ceiling space.
3. The venting system shall be installed in a conduit or enclosure with sealed joints separating the interior of the conduit or enclosure from the ceiling space.

**503.4 Type of venting system to be used.** The type of venting system to be used shall be in accordance with Table 503.4.

**TABLE 503.4  
TYPE OF VENTING SYSTEM TO BE USED**

APPLIANCES	TYPE OF VENTING SYSTEM
Listed Category I appliances Listed appliances equipped with draft hood Appliances listed for use with Type B gas vent	Type B gas vent (Section 503.6) Chimney (Section 503.5) Single-wall metal pipe (Section 503.7) Listed chimney lining system for gas venting (Section 503.5.3) Special gas vent listed for these appliances (Section 503.4.2)
Listed vented wall furnaces	Type B-W gas vent (Sections 503.6, 608)
Category II appliances	As specified or furnished by manufacturers of listed appliances (Sections 503.4.1, 503.4.2)
Category III appliances	As specified or furnished by manufacturers of listed appliances (Sections 503.4.1, 503.4.2)
Category IV appliances	As specified or furnished by manufacturers of listed appliances (Sections 503.4.1, 503.4.2)
Incinerators, indoors	Chimney (Section 503.5)
Incinerators, outdoors	Single-wall metal pipe (Sections 503.7, 503.7.6)
Appliances that can be converted for use with solid fuel	Chimney (Section 503.5)
Unlisted combination gas and oil-burning appliances	Chimney (Section 503.5)
Listed combination gas and oil-burning appliances	Type L vent (Section 503.6) or chimney (Section 503.5)
Combination gas and solid fuel-burning appliances	Chimney (Section 503.5)
Appliances listed for use with chimneys only	Chimney (Section 503.5)
Unlisted appliances	Chimney (Section 503.5)
Decorative appliances in vented fireplaces	Chimney
Gas-fired toilets	Single-wall metal pipe (Section 626)
Direct-vent appliances	See Section 503.2.3
Appliances with integral vent	See Section 503.2.4

**503.4.1 Plastic piping.** Plastic piping used for venting appliances listed for use with such venting materials shall be approved.

**503.4.2 Special gas vent.** Special gas vent shall be listed and installed in accordance with the special gas vent manufacturer’s installation instructions.

**503.5 Masonry, metal, and factory-built chimneys.** Masonry, metal and factory-built chimneys shall comply with Sections 503.5.1 through 503.5.10.

**503.5.1 Factory-built chimneys.** Factory-built chimneys shall be installed in accordance with the manufacturer’s installation instructions. Factory-built chimneys used to vent appliances that operate at a positive vent pressure shall be listed for such application.

**503.5.2 Metal chimneys.** Metal chimneys shall be built and installed in accordance with NFPA 211.

**503.5.3 Masonry chimneys.** Masonry chimneys shall be built and installed in accordance with NFPA 211 and shall be lined with approved clay flue lining, a listed chimney lining system or other approved material that will resist corrosion, erosion, softening or cracking from vent gases at temperatures up to 1,800°F (982°C).

**Exception:** Masonry chimney flues serving listed gas appliances with draft hoods, Category I appliances and other gas appliances listed for use with Type B vents shall be permitted to be lined with a chimney lining system specifically listed for use only with such appliances. The liner shall be installed in accordance with the liner manufacturer’s installation instructions. A permanent identifying label shall be attached at the point where the connection is to be made to the liner. The label shall read: “This chimney liner is for appliances that burn gas only. Do not connect to solid or liquid fuel-burning appliances or incinerators.”

For installation of gas vents in existing masonry chimneys, see Section 503.6.3.

**503.5.4 Chimney termination.** Chimneys for residential-type or low-heat appliances shall extend at least 3 feet (914 mm) above the highest point where they pass through a roof of a building and at least 2 feet (610 mm) higher than any portion of a building within a horizontal distance of 10 feet (3048 mm) (see Figure 503.5.4). Chimneys for medium-heat appliances shall extend at least 10 feet (3048 mm) higher than any portion of any building within 25 feet (7620 mm). Chimneys shall extend at least 5 feet (1524 mm) above the highest connected appliance draft hood outlet or flue collar. Decorative shrouds shall not be installed at the termination of factory-built chimneys except where such

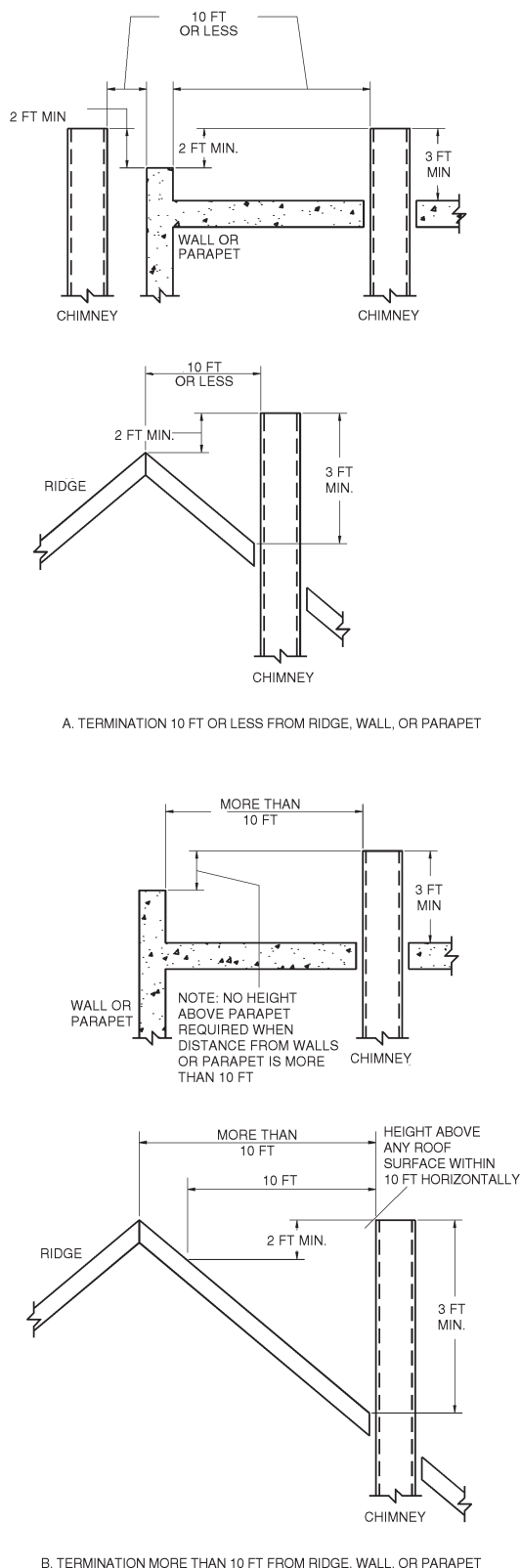

For SI: 1 inch = 25.4 mm, 1 foot = 304.8 mm.

**FIGURE 503.5.4**  
**TYPICAL TERMINATION LOCATIONS FOR**  
**CHIMNEYS AND SINGLE-WALL METAL PIPES SERVING**  
**RESIDENTIAL-TYPE AND LOW-HEAT EQUIPMENT**

shrouds are listed and labeled for use with the specific factory-built chimney system and are installed in accordance with the manufacturer’s installation instructions.

**503.5.5 Size of chimneys.** The effective area of a chimney venting system serving listed appliances with draft hoods, Category I appliances and other appliances listed for use with Type B vents shall be determined in accordance with one of the following methods:

1. The provisions of Section 504.
2. For sizing an individual chimney venting system for a single appliance with a draft hood, the effective areas of the vent connector and chimney flue shall be not less than the area of the appliance flue collar or draft hood outlet, nor greater than seven times the draft hood outlet area.
3. For sizing a chimney venting system connected to two appliances with draft hoods, the effective area of the chimney flue shall be not less than the area of the larger draft hood outlet plus 50 percent of the area of the smaller draft hood outlet, nor greater than seven times the smallest draft hood outlet area.
4. Chimney venting systems using mechanical draft shall be sized in accordance with approved engineering methods.
5. Other approved engineering methods.

**503.5.5.1 Incinerator venting.** Where an incinerator is vented by a chimney serving other appliances, the gas input to the incinerator shall not be included in calculating chimney size, provided that the chimney flue diameter is not less than 1 inch (25 mm) larger in equivalent diameter than the diameter of the incinerator flue outlet.

**503.5.6 Inspection of chimneys.** Before replacing an existing appliance or connecting a vent connector to a chimney, the chimney passageway shall be examined to ascertain that it is clear and free of obstructions and it shall be cleaned if previously used for venting solid or liquid fuel-burning appliances or fireplaces.

**503.5.6.1 Chimney lining.** Chimneys shall be lined in accordance with NFPA 211.

**Exception:** Existing chimneys shall be permitted to have their use continued when an appliance is replaced by an appliance of similar type, input rating, and efficiency.

**503.5.6.2 Cleanouts.** Cleanouts shall be examined to determine if they will remain tightly closed when not in use.

**503.5.6.3 Unsafe chimneys.** Where inspection reveals that an existing chimney is not safe for the intended application, it shall be repaired, rebuilt, lined, relined or replaced with a vent or chimney to conform to NFPA 211 and it shall be suitable for the appliances to be vented.

**503.5.7 Chimneys serving equipment burning other fuels.** Chimneys serving equipment burning other fuels shall comply with Sections 503.5.7.1 through 503.5.7.4.

**503.5.7.1 Solid fuel-burning appliances.** An appliance shall not be connected to a chimney flue serving a separate appliance designed to burn solid fuel.

**503.5.7.2 Liquid fuel-burning appliances.** Where one chimney flue serves gas appliances and liquid fuel-burning appliances, the appliances shall be connected through separate openings or shall be connected through a single opening where joined by a suitable fitting located as close as practical to the chimney. Where two or more openings are provided into one chimney flue, they shall be at different levels. Where the appliances are automatically controlled, they shall be equipped with safety shutoff devices.

**503.5.7.3 Combination gas and solid fuel-burning appliances.** A combination gas- and solid fuel-burning appliance shall be permitted to be connected to a single chimney flue where equipped with a manual reset device to shut off gas to the main burner in the event of sustained backdraft or flue gas spillage. The chimney flue shall be sized to properly vent the appliance.

**503.5.7.4 Combination gas- and oil fuel-burning appliances.** A listed combination gas- and oil fuel-burning appliance shall be permitted to be connected to a single chimney flue. The chimney flue shall be sized to properly vent the appliance.

**503.5.8 Support of chimneys.** All portions of chimneys shall be supported for the design and weight of the materials employed. Factory-built chimneys shall be supported and spaced in accordance with the manufacturer's installation instructions.

**503.5.9 Cleanouts.** Where a chimney that formerly carried flue products from liquid or solid fuel-burning appliances is used with an appliance using fuel gas, an accessible cleanout shall be provided. The cleanout shall have a tight-fitting cover and shall be installed so its upper edge is at least 6 inches (152 mm) below the lower edge of the lowest chimney inlet opening.

**503.5.10 Space surrounding lining or vent.** The remaining space surrounding a chimney liner, gas vent, special gas vent or plastic piping installed within a masonry chimney flue shall not be used to vent another appliance. The insertion of another liner or vent within the chimney as provided in this code and the liner or vent manufacturer's instructions shall not be prohibited.

The remaining space surrounding a chimney liner, gas vent, special gas vent or plastic piping installed within a masonry, metal or factory-built chimney shall not be used to supply combustion air. Such space shall not be prohibited from supplying combustion air to direct-vent appliances designed for installation in a solid fuel-burning fireplace and installed in accordance with the manufacturer's installation instructions.

**503.6 Gas vents.** Gas vents shall comply with Sections 503.6.1 through 503.6.12 (see Section 202, Definitions).

**503.6.1 Installation, general.** Gas vents shall be installed in accordance with the manufacturer's installation instructions.

**503.6.2 Type B-W vent capacity.** A Type B-W gas vent shall have a listed capacity not less than that of the listed vented wall furnace to which it is connected.

**503.6.3 Gas vents installed within masonry chimneys.** Gas vents installed within masonry chimneys shall be installed in accordance with the manufacturer's installation instructions. Gas vents installed within masonry chimneys shall be identified with a permanent label installed at the point where the vent enters the chimney. The label shall contain the following language: "This gas vent is for appliances that burn gas. Do not connect to solid or liquid fuel-burning appliances or incinerators."

**503.6.4 Gas vent terminations.** A gas vent shall terminate in accordance with one of the following:

1. Gas vents that are 12 inches (305 mm) or less in size and located not less than 8 feet (2438 mm) from a vertical wall or similar obstruction shall terminate above the roof in accordance with Figure 503.6.4.
2. Gas vents that are over 12 inches (305 mm) in size or are located less than 8 feet (2438 mm) from a vertical wall or similar obstruction shall terminate not less than 2 feet (610 mm) above the highest point where they pass through the roof and not less than 2 feet (610 mm) above any portion of a building within 10 feet (3048 mm) horizontally.
3. As provided for industrial appliances in Section 503.2.2.
4. As provided for direct-vent systems in Section 503.2.3.
5. As provided for appliances with integral vents in Section 503.2.4.
6. As provided for mechanical draft systems in Section 503.3.3.
7. As provided for ventilating hoods and exhaust systems in Section 503.3.4.

**503.6.4.1 Decorative shrouds.** Decorative shrouds shall not be installed at the termination of gas vents except where such shrouds are listed for use with the specific gas venting system and are installed in accordance with manufacturer's installation instructions.

**503.6.5 Minimum height.** A Type B or L gas vent shall terminate at least 5 feet (1524 mm) in vertical height above the highest connected appliance draft hood or flue collar. A Type B-W gas vent shall terminate at least 12 feet (3658 mm) in vertical height above the bottom of the wall furnace.

**503.6.6 Roof terminations.** Gas vents shall extend through the roof flashing, roof jack or roof thimble and terminate with a listed cap or listed roof assembly.

**503.6.7 Forced air inlets.** Gas vents shall terminate not less than 3 feet (914 mm) above any forced air inlet located within 10 feet (3048 mm).

**503.6.8 Exterior wall penetrations.** A gas vent extending through an exterior wall shall not terminate adjacent to the wall or below eaves or parapets, except as provided in Sections 503.2.3 and 503.3.3.

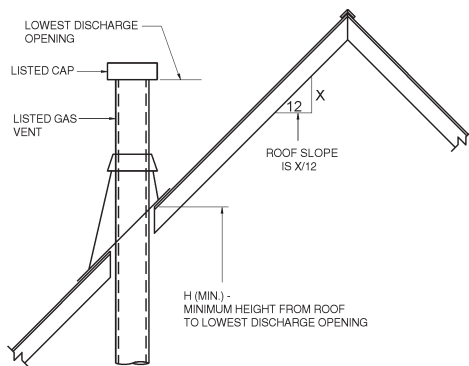

ROOF SLOPE	H (min) ft
Flat to 6/12	1.0
Over 6/12 to 7/12	1.25
Over 7/12 to 8/12	1.5
Over 8/12 to 9/12	2.0
Over 9/12 to 10/12	2.5
Over 10/12 to 11/12	3.25
Over 11/12 to 12/12	4.0
Over 12/12 to 14/12	5.0
Over 14/12 to 16/12	6.0
Over 16/12 to 18/12	7.0
Over 18/12 to 20/12	7.5
Over 20/12 to 21/12	8.0

For SI: 1 inch = 25.4 mm, 1 foot = 304.8 mm.

**FIGURE 503.6.4**  
**TERMINATION LOCATIONS FOR GAS VENTS WITH LISTED CAPS 12 INCHES OR LESS IN SIZE AT LEAST 8 FEET FROM A VERTICAL WALL**

**503.6.9 Size of gas vents.** Venting systems shall be sized and constructed in accordance with Section 504 or other approved engineering methods and the gas vent and appliance manufacturer’s installation instructions.

**503.6.9.1 Category I appliances.** The sizing of natural draft venting systems serving one or more listed appliances equipped with a draft hood or appliances listed for use with Type B gas vent, installed in a single story of a building, shall be in accordance with one of the following methods:

1. The provisions of Section 504.
2. For sizing an individual gas vent for a single, draft-hood-equipped appliance, the effective area of the vent connector and the gas vent shall be not less than the area of the appliance draft hood outlet, nor greater than seven times the draft hood outlet area.
3. For sizing a gas vent connected to two appliances with draft hoods, the effective area of the vent shall be not less than the area of the larger draft hood

outlet plus 50 percent of the area of the smaller draft hood outlet, nor greater than seven times the smaller draft hood outlet area.

4. Approved engineering practices.

**503.6.9.2 Vent offsets.** Type B and L vents sized in accordance with Item 2 or 3 of Section 503.6.9.1 shall extend in a generally vertical direction with offsets not exceeding 45 degrees (0.79 rad), except that a vent system having not more than one 60-degree (1.04 rad) offset shall be permitted. Any angle greater than 45 degrees (0.79 rad) from the vertical is considered horizontal. The total horizontal distance of a vent plus the horizontal vent connector serving draft hood-equipped appliances shall be not greater than 75 percent of the vertical height of the vent.

**503.6.9.3 Category II, III and IV appliances.** The sizing of gas vents for Category II, III and IV appliances shall be in accordance with the appliance manufacturer’s instructions.

**503.6.9.4 Mechanical draft.** Chimney venting systems using mechanical draft shall be sized in accordance with approved engineering methods.

**503.6.10 Gas vents serving appliances on more than one floor.** A common gas vent shall be permitted in multistory installations to vent Category I appliances located on more than one floor level, provided that the venting system is designed and installed in accordance with approved engineering methods. For the purpose of this section, crawl spaces, basements and attics shall be considered as floor levels.

**503.6.10.1 Appliance separation.** All appliances connected to the common vent shall be located in rooms separated from occupiable space. Each of these rooms shall have provisions for an adequate supply of combustion, ventilation and dilution air that is not supplied from an occupiable space (see Figure 503.6.10.1).

**503.6.10.2 Sizing.** The size of the connectors and common segments of multistory venting systems for appliances listed for use with Type B double-wall gas vents shall be in accordance with Table 504.3(1), provided that:

1. The available total height (*H*) for each segment of a multistory venting system is the vertical distance between the level of the highest draft hood outlet or flue collar on that floor and the centerline of the next highest interconnection tee (see Figure B-13).
2. The size of the connector for a segment is determined from the appliance input rating and available connector rise, and shall not be smaller than the draft hood outlet or flue collar size.
3. The size of the common vertical segment, and of the interconnection tee at the base of that segment, shall be based on the total appliance input rating entering that segment and its available total height.

**503.6.11 Support of gas vents.** Gas vents shall be supported and spaced in accordance with the manufacturer’s installation instructions.

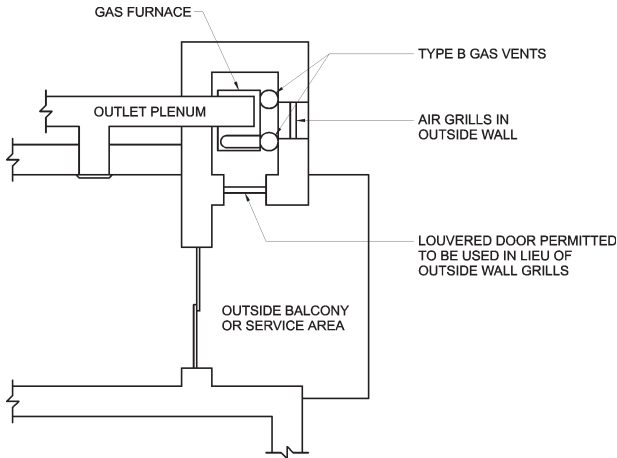

**FIGURE 503.6.10.1  
PLAN VIEW OF PRACTICAL SEPARATION METHOD  
FOR MULTISTORY GAS VENTING**

**503.6.12 Marking.** In those localities where solid and liquid fuels are used extensively, gas vents shall be permanently identified by a label attached to the wall or ceiling at a point where the vent connector enters the gas vent. The determination of where such localities exist shall be made by the code official. The label shall read:

“This gas vent is for appliances that burn gas. Do not connect to solid or liquid fuel-burning appliances or incinerators.”

**503.7 Single-wall metal pipe.** Single-wall metal pipe vents shall comply with Sections 503.7.1 through 503.7.12.

**503.7.1 Construction.** Single-wall metal pipe shall be constructed of galvanized sheet steel not less than 0.0304 inch (0.7 mm) thick, or other approved, noncombustible, corrosion-resistant material.

**503.7.2 Cold climate.** Uninsulated single-wall metal pipe shall not be used outdoors for venting appliances in regions where the 99-percent winter design temperature is below 32°F (0°C).

**503.7.3 Termination.** Single-wall metal pipe shall terminate at least 5 feet (1524 mm) in vertical height above the highest connected appliance draft hood outlet or flue collar. Single-wall metal pipe shall extend at least 2 feet (610 mm) above the highest point where it passes through a roof of a building and at least 2 feet (610 mm) higher than any portion of a building within a horizontal distance of 10 feet (3048 mm) (see Figure 503.5.4). An approved cap or roof assembly shall be attached to the terminus of a single-wall metal pipe (see also Section 503.7.8, Item 3).

**503.7.4 Limitations of use.** Single-wall metal pipe shall be used only for runs directly from the space in which the appliance is located through the roof or exterior wall to the outdoor atmosphere.

**503.7.5 Roof penetrations.** A pipe passing through a roof shall extend without interruption through the roof flashing, roof jack, or roof thimble. Where a single-wall metal pipe passes through a roof constructed of combustible material, a noncombustible, nonventilating thimble shall be used at the point of passage. The thimble shall extend at least 18 inches (457 mm) above and 6 inches (152 mm) below the roof with

the annular space open at the bottom and closed only at the top. The thimble shall be sized in accordance with Section 503.10.15.

**503.7.6 Installation.** Single-wall metal pipe shall not originate in any unoccupied attic or concealed space and shall not pass through any attic, inside wall, concealed space or floor. The installation of a single-wall metal pipe through an exterior combustible wall shall comply with Section 503.10.15. Single-wall metal pipe used for venting an incinerator shall be exposed and readily examinable for its full length and shall have suitable clearances maintained.

**503.7.7 Clearances.** Minimum clearances from single-wall metal pipe to combustible material shall be in accordance with Table 503.7.7. The clearance from single-wall metal pipe to combustible material shall be permitted to be reduced where the combustible material is protected as specified for vent connectors in Table 308.2.

**503.7.8 Size of single-wall metal pipe.** A venting system constructed of single-wall metal pipe shall be sized in accordance with one of the following methods and the appliance manufacturer’s instructions:

1. For a draft-hood-equipped appliance, in accordance with Section 504.
2. For a venting system for a single appliance with a draft hood, the areas of the connector and the pipe each shall be not less than the area of the appliance flue collar or draft hood outlet, whichever is smaller. The vent area shall not be greater than seven times the draft hood outlet area.
3. Other approved engineering methods.

**503.7.9 Pipe geometry.** Any shaped single-wall metal pipe shall be permitted to be used, provided that its equivalent effective area is equal to the effective area of the round pipe for which it is substituted, and provided that the minimum internal dimension of the pipe is not less than 2 inches (51 mm).

**503.7.10 Termination capacity.** The vent cap or a roof assembly shall have a venting capacity not less than that of the pipe to which it is attached.

**503.7.11 Support of single-wall metal pipe.** All portions of single-wall metal pipe shall be supported for the design and weight of the material employed.

**503.7.12 Marking.** Single-wall metal pipe shall comply with the marking provisions of Section 503.6.12.

**503.8 Venting system termination location.** The location of venting system terminations shall comply with the following (see Appendix C):

1. A mechanical draft venting system shall terminate at least 3 feet (914 mm) above any forced-air inlet located within 10 feet (3048 mm).

**Exceptions:**

1. This provision shall not apply to the combustion air intake of a direct-vent appliance.
2. This provision shall not apply to the separation of the integral outdoor air inlet and flue gas discharge of listed outdoor appliances.



TABLE 503.7.7<sup>a</sup>  
CLEARANCES FOR CONNECTORS

APPLIANCE	MINIMUM DISTANCE FROM COMBUSTIBLE MATERIAL			
	Listed Type B gas vent material	Listed Type L vent material	Single-wall metal pipe	Factory-built chimney sections
Listed appliances with draft hoods and appliances listed for use with Type B gas vents	As listed	As listed	6 inches	As listed
Residential boilers and furnaces with listed gas conversion burner and with draft hood	6 inches	6 inches	9 inches	As listed
Residential appliances listed for use with Type L vents	Not permitted	As listed	9 inches	As listed
Listed gas-fired toilets	Not permitted	As listed	As listed	As listed
Unlisted residential appliances with draft hood	Not permitted	6 inches	9 inches	As listed
Residential and low-heat appliances other than above	Not permitted	9 inches	18 inches	As listed
Medium-heat appliances	Not permitted	Not permitted	36 inches	As listed

For SI: 1 inch = 25.4 mm.

a. These clearances shall apply unless the manufacturer’s installation instructions for a listed appliance or connector specify different clearances, in which case the listed clearances shall apply.

2. A mechanical draft venting system, excluding direct-vent appliances, shall terminate at least 4 feet (1219 mm) below, 4 feet (1219 mm) horizontally from, or 1 foot (305 mm) above any door, operable window, or gravity air inlet into any building. The bottom of the vent terminal shall be located at least 12 inches (305 mm) above grade.
3. The vent terminal of a direct-vent appliance with an input of 10,000 Btu per hour (3 kW) or less shall be located at least 6 inches (152 mm) from any air opening into a building, and such an appliance with an input over 10,000 Btu per hour (3 kW) but not over 50,000 Btu per hour (14.7 kW) shall be installed with a 9-inch (230 mm) vent termination clearance, and an appliance with an input over 50,000 Btu/h (14.7 kw) shall have at least a 12-inch (305 mm) vent termination clearance. The bottom of the vent terminal and the air intake shall be located at least 12 inches (305 mm) above grade.
4. Through-the-wall vents for Category II and IV appliances and noncategorized condensing appliances shall not terminate over public walkways or over an area where condensate or vapor could create a nuisance or hazard or could be detrimental to the operation of regulators, relief valves, or other equipment. Where local experience indicates that condensate is a problem with Category I and III appliances, this provision shall also apply.

**503.9 Condensation drainage.** Provisions shall be made to collect and dispose of condensate from venting systems serving Category II and IV appliances and noncategorized condensing appliances in accordance with Section 503.8, Item 4. Where local experience indicates that condensation is a problem, provision shall be made to drain off and dispose of condensate from venting systems serving Category I and III appliances in accordance with Section 503.8, Item 4.

**503.10 Vent connectors for Category I equipment.** Vent connectors for Category I equipment shall comply with Sections 503.10.1 through 503.10.16.

**503.10.1 Where required.** A vent connector shall be used to connect an appliance to a gas vent, chimney or single-wall

metal pipe, except where the gas vent, chimney or single-wall metal pipe is directly connected to the appliance.

**503.10.2 Materials.** Vent connectors shall be constructed in accordance with Sections 503.10.2.1 through 503.10.2.5.

**503.10.2.1 General.** A vent connector shall be made of noncombustible corrosion-resistant material capable of withstanding the vent gas temperature produced by the appliance and of sufficient thickness to withstand physical damage.

**503.10.2.2 Vent connectors located in unconditioned areas.** Where the vent connector used for an appliance having a draft hood or a Category I appliance is located in or passes through attics, crawl spaces or other unconditioned spaces, that portion of the vent connector shall be listed Type B, Type L or listed vent material having equivalent insulation properties.

**Exception:** Single-wall metal pipe located within the exterior walls of the building in areas having a local 99-percent winter design temperature of 5°F (-15°C) or higher shall be permitted to be used in unconditioned spaces other than attics and crawl spaces.

**503.10.2.3 Residential-type appliance connectors.** Where vent connectors for residential-type appliances are not installed in attics or other unconditioned spaces, connectors for listed appliances having draft hoods, appliances having draft hoods and equipped with listed conversion burners and Category I appliances shall be one of the following:

1. Type B or L vent material;
2. Galvanized sheet steel not less than 0.018 inch (0.46 mm) thick;
3. Aluminum (1100 or 3003 alloy or equivalent) sheet not less than 0.027 inch (0.69 mm) thick;
4. Stainless steel sheet not less than 0.012 inch (0.31 mm) thick;

5. Smooth interior wall metal pipe having resistance to heat and corrosion equal to or greater than that of Item 2, 3 or 4 above; or
6. A listed vent connector.

Vent connectors shall not be covered with insulation.

**Exception:** Listed insulated vent connectors shall be installed according to the terms of their listing.

**503.10.2.4 Low-heat equipment.** A vent connector for a nonresidential, low-heat appliance shall be a factory-built chimney section or steel pipe having resistance to heat and corrosion equivalent to that for the appropriate galvanized pipe as specified in Table 503.10.2.4. Factory-built chimney sections shall be joined together in accordance with the chimney manufacturer's instructions.

**TABLE 503.10.2.4  
MINIMUM THICKNESS FOR GALVANIZED STEEL VENT  
CONNECTORS FOR LOW-HEAT APPLIANCES**

DIAMETER OF CONNECTOR (inches)	MINIMUM THICKNESS (inch)
Less than 6	0.019
6 to less than 10	0.023
10 to 12 inclusive	0.029
14 to 16 inclusive	0.034
Over 16	0.056

For SI: 1 inch = 25.4 mm.

**503.10.2.5 Medium-heat appliances.** Vent connectors for medium-heat appliances and commercial and industrial incinerators shall be constructed of factory-built medium-heat chimney sections or steel of a thickness not less than that specified in Table 503.10.2.5 and shall comply with the following:

1. A steel vent connector for an appliance with a vent gas temperature in excess of 1,000°F (538°C) measured at the entrance to the connector shall be lined with medium-duty fire brick (ASTM C 64, Type F), or the equivalent.
2. The lining shall be at least 2½ inches (64 mm) thick for a vent connector having a diameter or greatest cross-sectional dimension of 18 inches (457 mm) or less.
3. The lining shall be at least 4½ inches (114 mm) thick laid on the 4½-inch (114 mm) bed for a vent connector having a diameter or greatest cross-sectional dimension greater than 18 inches (457 mm).
4. Factory-built chimney sections, if employed, shall be joined together in accordance with the chimney manufacturer's instructions.

**503.10.3 Size of vent connector.** Vent connectors shall be sized in accordance with Sections 503.10.3.1 through 503.10.3.5.

**503.10.3.1 Single draft hood and fan-assisted.** A vent connector for an appliance with a single draft hood or for a Category I fan-assisted combustion system appliance

shall be sized and installed in accordance with Section 504 or other approved engineering methods.

**TABLE 503.10.2.5  
MINIMUM THICKNESS FOR STEEL VENT CONNECTORS FOR  
MEDIUM-HEAT APPLIANCES AND COMMERCIAL AND  
INDUSTRIAL INCINERATORS VENT CONNECTOR SIZE**

DIAMETER (inches)	AREA (square inches)	MINIMUM THICKNESS (inch)
Up to 14	Up to 154	0.053
Over 14 to 16	154 to 201	0.067
Over 16 to 18	201 to 254	0.093
Over 18	Larger than 254	0.123

For SI: 1 inch = 25.4 mm, 1 square inch = 645.16 mm².

**503.10.3.2 Multiple draft hood.** For a single appliance having more than one draft hood outlet or flue collar, the manifold shall be constructed according to the instructions of the appliance manufacturer. Where there are no instructions, the manifold shall be designed and constructed in accordance with approved engineering practices. As an alternate method, the effective area of the manifold shall equal the combined area of the flue collars or draft hood outlets and the vent connectors shall have a minimum 1-foot (305 mm) rise.

**503.10.3.3 Multiple appliances.** Where two or more appliances are connected to a common vent or chimney, each vent connector shall be sized in accordance with Section 504 or other approved engineering methods.

As an alternative method applicable only when all of the appliances are draft hood equipped, each vent connector shall have an effective area not less than the area of the draft hood outlet of the appliance to which it is connected.

**503.10.3.4 Common connector/manifold.** Where two or more appliances are vented through a common vent connector or vent manifold, the common vent connector or vent manifold shall be located at the highest level consistent with available headroom and the required clearance to combustible materials and shall be sized in accordance with Section 504 or other approved engineering methods.

As an alternate method applicable only where there are two draft hood-equipped appliances, the effective area of the common vent connector or vent manifold and all junction fittings shall be not less than the area of the larger vent connector plus 50 percent of the area of the smaller flue collar outlet.

**503.10.3.5 Size increase.** Where the size of a vent connector is increased to overcome installation limitations and obtain connector capacity equal to the appliance input, the size increase shall be made at the appliance draft hood outlet.

**503.10.4 Two or more appliances connected to a single vent.** Where two or more vent connectors enter a common gas vent, chimney flue, or single-wall metal pipe, the smaller connector shall enter at the highest level consistent with the available headroom or clearance to combustible material. Vent connectors serving Category I appliances

shall not be connected to any portion of a mechanical draft system operating under positive static pressure, such as those serving Category III or IV appliances.

**503.10.5 Clearance.** Minimum clearances from vent connectors to combustible material shall be in accordance with Table 503.7.7.

**Exception:** The clearance between a vent connector and combustible material shall be permitted to be reduced where the combustible material is protected as specified for vent connectors in Table 308.2.

**503.10.6 Flow resistance.** A vent connector shall be installed so as to avoid turns or other construction features that create excessive resistance to flow of vent gases.

**503.10.7 Joints.** Joints between sections of connector piping and connections to flue collars and draft hood outlets shall be fastened by one of the following methods:

1. Sheet metal screws.
2. Vent connectors of listed vent material assembled and connected to flue collars or draft hood outlets in accordance with the manufacturers' instructions.
3. Other approved means.

**503.10.8 Slope.** A vent connector shall be installed without dips or sags and shall slope upward toward the vent or chimney at least  $\frac{1}{4}$  inch per foot (21 mm/m).

**Exception:** Vent connectors attached to a mechanical draft system installed in accordance with the manufacturers' instructions.

**503.10.9 Length of vent connector.** A vent connector shall be as short as practical and the appliance located as close as practical to the chimney or vent. The maximum horizontal length of a single-wall connector shall be 75 percent of the height of the chimney or vent except for engineered systems. The maximum horizontal length of a Type B double-wall connector shall be 100 percent of the height of the chimney or vent except for engineered systems. For a chimney or vent system serving multiple appliances, the maximum length of an individual connector, from the appliance outlet to the junction with the common vent or another connector, shall be 100 percent of the height of the chimney or vent.

**503.10.10 Support.** A vent connector shall be supported for the design and weight of the material employed to maintain clearances and prevent physical damage and separation of joints.

**503.10.11 Chimney connection.** Where entering a flue in a masonry or metal chimney, the vent connector shall be installed above the extreme bottom to avoid stoppage. Where a thimble or slip joint is used to facilitate removal of the connector, the connector shall be firmly attached to or inserted into the thimble or slip joint to prevent the connector from falling out. Means shall be employed to prevent the connector from entering so far as to restrict the space between its end and the opposite wall of the chimney flue (see Section 501.9).

**503.10.12 Inspection.** The entire length of a vent connector shall be provided with ready access for inspection, cleaning and replacement.

**503.10.13 Fireplaces.** A vent connector shall not be connected to a chimney flue serving a fireplace unless the fireplace flue opening is permanently sealed.

**503.10.14 Passage through ceilings, floors or walls.** Single-wall metal pipe connectors shall not pass through any wall, floor or ceiling except as permitted by Sections 503.7.4 and 503.10.15.

**503.10.15 Single-wall connector penetrations of combustible walls.** A vent connector made of a single-wall metal pipe shall not pass through a combustible exterior wall unless guarded at the point of passage by a ventilated metal thimble not smaller than the following:

1. For listed appliances equipped with draft hoods and appliances listed for use with Type B gas vents, the thimble shall be not less than 4 inches (102 mm) larger in diameter than the vent connector. Where there is a run of not less than 6 feet (1829 mm) of vent connector in the open between the draft hood outlet and the thimble, the thimble shall be permitted to be not less than 2 inches (51 mm) larger in diameter than the vent connector.
2. For unlisted appliances having draft hoods, the thimble shall be not less than 6 inches (152 mm) larger in diameter than the vent connector.
3. For residential and low-heat appliances, the thimble shall be not less than 12 inches (305 mm) larger in diameter than the vent connector.

**Exception:** In lieu of thimble protection, all combustible material in the wall shall be removed from the vent connector a sufficient distance to provide the specified clearance from such vent connector to combustible material. Any material used to close up such opening shall be noncombustible.

**503.10.16 Medium-heat connectors.** Vent connectors for medium-heat appliances shall not pass through walls or partitions constructed of combustible material.

**503.11 Vent connectors for Category II, III and IV appliances.** Vent connectors for Category II, III and IV appliances shall be as specified for the venting systems in accordance with Section 503.4.

**503.12 Draft hoods and draft controls.** The installation of draft hoods and draft controls shall comply with Sections 503.12.1 through 503.12.7.

**503.12.1 Appliances requiring draft hoods.** Vented appliances shall be installed with draft hoods.

**Exception:** Dual oven-type combination ranges; incinerators; direct-vent appliances; fan-assisted combustion system appliances; appliances requiring chimney draft for operation; single firebox boilers equipped with conversion burners with inputs greater than 400,000 Btu per hour (117 kw); appliances equipped with blast, power or pressure burners that are not listed for use with draft hoods; and appliances designed for forced venting.

**503.12.2 Installation.** A draft hood supplied with or forming a part of a listed vented appliance shall be installed with-

out alteration, exactly as furnished and specified by the appliance manufacturer.

**503.12.2.1 Draft hood required.** If a draft hood is not supplied by the appliance manufacturer where one is required, a draft hood shall be installed, shall be of a listed or approved type and, in the absence of other instructions, shall be of the same size as the appliance flue collar. Where a draft hood is required with a conversion burner, it shall be of a listed or approved type.

**503.12.2.2 Special design draft hood.** Where it is determined that a draft hood of special design is needed or preferable for a particular installation, the installation shall be in accordance with the recommendations of the appliance manufacturer and shall be approved.

**503.12.3 Draft control devices.** Where a draft control device is part of the appliance or is supplied by the appliance manufacturer, it shall be installed in accordance with the manufacturer's instructions. In the absence of manufacturer's instructions, the device shall be attached to the flue collar of the appliance or as near to the appliance as practical.

**503.12.4 Additional devices.** Appliances (except incinerators) requiring a controlled chimney draft shall be permitted to be equipped with a listed double-acting barometric-draft regulator installed and adjusted in accordance with the manufacturer's instructions.

**503.12.5 Location.** Draft hoods and barometric draft regulators shall be installed in the same room or enclosure as the appliance in such a manner as to prevent any difference in pressure between the hood or regulator and the combustion air supply.

**503.12.6 Positioning.** Draft hoods and draft regulators shall be installed in the position for which they were designed with reference to the horizontal and vertical planes and shall be located so that the relief opening is not obstructed by any part of the appliance or adjacent construction. The appliance and its draft hood shall be located so that the relief opening is accessible for checking vent operation.

**503.12.7 Clearance.** A draft hood shall be located so its relief opening is not less than 6 inches (152 mm) from any surface except that of the appliance it serves and the venting system to which the draft hood is connected. Where a greater or lesser clearance is indicated on the appliance label, the clearance shall be not less than that specified on the label. Such clearances shall not be reduced.

**503.13 Manually operated dampers.** A manually operated damper shall not be placed in the vent connector for any appliance. Fixed baffles shall not be classified as manually operated dampers.

**503.14 Automatically operated vent dampers.** An automatically operated vent damper shall be of a listed type.

**503.15 Obstructions.** Devices that retard the flow of vent gases shall not be installed in a vent connector, chimney or vent. The following shall not be considered as obstructions:

1. Draft regulators and safety controls specifically listed for installation in venting systems and installed in accordance with the manufacturer's installation instructions.

2. Approved draft regulators and safety controls that are designed and installed in accordance with approved engineering methods.
3. Listed heat reclaimers and automatically operated vent dampers installed in accordance with the manufacturer's installation instructions.
4. Approved economizers, heat reclaimers and recuperators installed in venting systems of appliances not required to be equipped with draft hoods, provided that the appliance manufacturer's instructions cover the installation of such a device in the venting system and performance in accordance with Sections 503.3 and 503.3.1 is obtained.
5. Vent dampers serving listed appliances installed in accordance with Sections 504.2.1 and 504.3.1 or other approved engineering methods.

### SECTION 504 (IFGS) SIZING OF CATEGORY I APPLIANCE VENTING SYSTEMS

**504.1 Definitions.** The following definitions apply to the tables in this section.

**APPLIANCE CATEGORIZED VENT DIAMETER/AREA.** The minimum vent area/diameter permissible for Category I appliances to maintain a nonpositive vent static pressure when tested in accordance with nationally recognized standards.

**FAN-ASSISTED COMBUSTION SYSTEM.** An appliance equipped with an integral mechanical means to either draw or force products of combustion through the combustion chamber or heat exchanger.

**FAN Min.** The minimum input rating of a Category I fan-assisted appliance attached to a vent or connector.

**FAN Max.** The maximum input rating of a Category I fan-assisted appliance attached to a vent or connector.

**NAT Max.** The maximum input rating of a Category I draft-hood-equipped appliance attached to a vent or connector.

**FAN + FAN.** The maximum combined appliance input rating of two or more Category I fan-assisted appliances attached to the common vent.

**FAN + NAT.** The maximum combined appliance input rating of one or more Category I fan-assisted appliances and one or more Category I draft-hood-equipped appliances attached to the common vent.

**NA.** Vent configuration is not allowed due to potential for condensate formation or pressurization of the venting system, or not applicable due to physical or geometric restraints.

**NAT + NAT.** The maximum combined appliance input rating of two or more Category I draft-hood-equipped appliances attached to the common vent.

**504.2 Application of single-appliance vent Tables 504.2(1) through 504.2(6).** The application of Tables 504.2(1) through 504.2(6) shall be subject to the requirements of Sections 504.2.1 through 504.2.16.

**504.2.1 Vent obstructions.** These venting tables shall not be used where obstructions, as described in Section 503.15,

are installed in the venting system. The installation of vents serving listed appliances with vent dampers shall be in accordance with the appliance manufacturer's instructions or in accordance with the following:

1. The maximum capacity of the vent system shall be determined using the "NAT Max" column.
2. The minimum capacity shall be determined as if the appliance were a fan-assisted appliance, using the "FAN Min" column to determine the minimum capacity of the vent system. Where the corresponding "FAN Min" is "NA," the vent configuration shall not be permitted and an alternative venting configuration shall be utilized.

**504.2.2 Minimum size.** Where the vent size determined from the tables is smaller than the appliance draft hood outlet or flue collar, the smaller size shall be permitted to be used provided that all of the following requirements are met:

1. The total vent height ( $H$ ) is at least 10 feet (3048 mm).
2. Vents for appliance draft hood outlets or flue collars 12 inches (305 mm) in diameter or smaller are not reduced more than one table size.
3. Vents for appliance draft hood outlets or flue collars larger than 12 inches (305 mm) in diameter are not reduced more than two table sizes.
4. The maximum capacity listed in the tables for a fan-assisted appliance is reduced by 10 percent ( $0.90 \times$  maximum table capacity).
5. The draft hood outlet is greater than 4 inches (102 mm) in diameter. Do not connect a 3-inch-diameter (76 mm) vent to a 4-inch-diameter (102 mm) draft hood outlet. This provision shall not apply to fan-assisted appliances.

**504.2.3 Vent offsets.** Single-appliance venting configurations with zero (0) lateral lengths in Tables 504.2(1), 504.2(2) and 504.2(5) shall not have elbows in the venting system. Single-appliance venting configurations with lateral lengths include two 90-degree (1.57 rad) elbows. For each additional elbow up to and including 45 degrees (0.79 rad), the maximum capacity listed in the venting tables shall be reduced by 5 percent. For each additional elbow greater than 45 degrees (0.79 rad) up to and including 90 degrees (1.57 rad), the maximum capacity listed in the venting tables shall be reduced by 10 percent.

**504.2.4 Zero lateral.** Zero (0) lateral ( $L$ ) shall apply only to a straight vertical vent attached to a top outlet draft hood or flue collar.

**504.2.5 High-altitude installations.** Sea-level input ratings shall be used when determining maximum capacity for high altitude installation. Actual input (derated for altitude) shall be used for determining minimum capacity for high altitude installation.

**504.2.6 Multiple input rate appliances.** For appliances with more than one input rate, the minimum vent capacity (FAN Min) determined from the tables shall be less than the lowest appliance input rating, and the maximum vent capacity

(FAN Max/NAT Max) determined from the tables shall be greater than the highest appliance rating input.

**504.2.7 Liner system sizing and connections.** Listed corrugated metallic chimney liner systems in masonry chimneys shall be sized by using Table 504.2(1) or 504.2(2) for Type B vents with the maximum capacity reduced by 20 percent ( $0.80 \times$  maximum capacity) and the minimum capacity as shown in Table 504.2(1) or 504.2(2). Corrugated metallic liner systems installed with bends or offsets shall have their maximum capacity further reduced in accordance with Section 504.2.3. The 20-percent reduction for corrugated metallic chimney liner systems includes an allowance for one long-radius 90-degree (1.57 rad) turn at the bottom of the liner.

Connections between chimney liners and listed double-wall connectors shall be made with listed adapters designed for such purpose.

**504.2.8 Vent area and diameter.** Where the vertical vent has a larger diameter than the vent connector, the vertical vent diameter shall be used to determine the minimum vent capacity, and the connector diameter shall be used to determine the maximum vent capacity. The flow area of the vertical vent shall not exceed seven times the flow area of the listed appliance categorized vent area, flue collar area, or draft hood outlet area unless designed in accordance with approved engineering methods.

**504.2.9 Chimney and vent locations.** Tables 504.2(1), 504.2(2), 504.2(3), 504.2(4) and 504.2(5) shall only be used for chimneys and vents not exposed to the outdoors below the roof line. A Type B vent or listed chimney lining system passing through an unused masonry chimney flue shall not be considered to be exposed to the outdoors. A Type B vent shall not be considered to be exposed to the outdoors where it passes through an unventilated enclosure or chase insulated to a value of not less than R8.

Table 504.2(3) in combination with Table 504.2(6) shall be used for clay-tile-lined exterior masonry chimneys, provided that all of the following are met:

1. Vent connector is a Type B double wall.
2. Vent connector length is limited to  $1\frac{1}{2}$  feet for each inch (18 mm per mm) of vent connector diameter.
3. The appliance is draft hood equipped.
4. The input rating is less than the maximum capacity given by Table 504.2(3).
5. For a water heater, the outdoor design temperature is not less than  $5^{\circ}\text{F}$  ( $-15^{\circ}\text{C}$ ).
6. For a space-heating appliance, the input rating is greater than the minimum capacity given by Table 504.2(6).

Where these conditions cannot be met, an alternative venting design shall be used, such as a listed chimney lining system.

**Exception:** The installation of vents serving listed appliances shall be permitted to be in accordance with the appliance manufacturer's installation instructions.

Number of Appliances	Single
Appliance Type	Category I
Appliance Vent Connection	Connected directly to vent

TABLE 504.2(1)  
TYPE B DOUBLE-WALL GAS VENT

HEIGHT (H) (feet)	LATERAL (L) (feet)	VENT DIAMETER—(D) inches																					
		3			4			5			6			7			8			9			
		FAN		NAT	FAN		NAT	FAN		NAT	FAN		NAT	FAN		NAT	FAN		NAT	FAN		NAT	
APPLIANCE INPUT RATING IN THOUSANDS OF BTU/H		Min	Max	Min	Max	Min	Max	Min	Max	Min	Max	Min	Max	Min	Max	Min	Max	Min	Max	Min	Max		
6	0	0	78	46	86	0	152	86	251	141	0	375	205	0	524	285	0	698	370	0	897	470	
	2	13	51	36	67	27	157	105	32	232	157	44	321	217	44	321	217	53	425	285	63	543	370
	4	21	49	34	94	39	153	103	50	227	153	66	316	211	66	316	211	79	419	279	93	536	362
	6	25	46	32	91	61	149	100	59	223	149	78	310	205	78	310	205	93	413	273	110	530	354
8	0	0	84	50	94	0	165	94	276	155	0	415	235	0	583	320	0	780	415	0	1,006	537	
	2	12	57	40	75	25	178	120	28	263	180	42	365	247	42	365	247	50	483	322	60	619	418
	5	23	53	38	103	71	187	124	41	280	188	68	392	263	70	356	237	83	473	313	99	607	407
	8	28	49	35	98	66	164	109	64	247	165	84	347	227	84	347	227	99	463	303	117	596	396
10	0	0	88	53	100	0	175	100	295	166	0	447	255	0	631	345	0	847	450	0	1,096	585	
	2	12	61	42	81	23	194	129	26	289	195	40	402	273	40	402	273	48	533	355	57	684	457
	5	23	57	40	113	77	187	124	41	280	188	68	392	263	68	392	263	81	522	346	95	671	446
	10	30	51	36	104	70	176	115	67	267	175	88	376	245	88	376	245	104	504	330	122	651	427
15	0	0	94	58	112	0	327	187	0	502	285	0	716	390	0	970	525	0	970	525	0	1,263	682
	2	11	69	48	93	20	226	150	22	339	225	38	475	316	38	475	316	45	633	414	53	815	544
	5	22	65	45	130	87	219	142	49	330	217	64	463	300	64	463	300	76	620	403	90	800	529
	10	29	59	41	121	82	206	135	64	315	208	84	445	288	84	445	288	99	600	386	116	777	507
20	15	35	53	37	112	76	195	128	76	301	198	98	429	275	98	429	275	115	580	373	134	755	491
	0	0	97	61	119	0	349	202	0	540	307	0	776	430	0	1,057	575	0	1,057	575	0	1,384	752
	2	10	75	51	149	18	250	166	20	377	249	33	531	346	33	531	346	41	711	470	50	917	612
	5	21	71	48	143	96	242	160	47	367	241	62	519	337	62	519	337	73	697	460	86	902	599
20	10	28	64	44	133	89	229	150	62	351	228	81	499	321	81	499	321	95	675	443	112	877	576
	15	34	58	40	124	84	217	142	73	337	217	94	481	308	94	481	308	111	654	427	129	853	557
	20	48	52	35	116	78	206	134	84	322	206	107	464	295	107	464	295	125	634	410	145	830	537

(continued)

Number of Appliances	Single
Appliance Type	Category I
Appliance Vent Connection	Connected directly to vent

TABLE 504.2(1)—continued  
TYPE B DOUBLE-WALL GAS VENT

HEIGHT (H) (feet)	LATERAL (L) (feet)	VENT DIAMETER—(D) inches																						
		3			4			5			6			7			8			9				
		FAN		NAT	FAN		NAT	FAN		NAT	FAN		NAT	FAN		NAT	FAN		NAT	FAN		NAT		
		Min	Max	Min	Max	Min	Max	Min	Max	Min	Max	Min	Max	Min	Max	Min	Max	Min	Max	Min	Max	Min	Max	
30	0	0	100	64	128	0	213	128	220	0	374	220	587	336	0	853	475	0	1,173	650	0	1,548	855	
	2	9	81	56	112	14	166	112	185	18	283	185	432	280	27	613	394	33	826	535	42	1,072	700	
	5	21	77	54	108	36	160	108	176	45	275	176	421	273	58	600	385	69	811	524	82	1,055	688	
	10	27	70	50	102	48	150	102	171	59	262	171	405	261	77	580	371	91	788	507	107	1,028	668	
	15	33	64	NA	NA	96	141	96	163	70	249	163	389	249	90	560	357	105	765	490	124	1,002	648	
	20	56	58	NA	NA	90	132	90	154	80	237	154	374	237	102	542	343	119	743	473	139	977	628	
50	30	NA	NA	NA	NA	73	113	NA	NA	88	214	NA	104	219	131	507	321	149	702	444	171	929	594	
	0	0	101	67	134	0	216	134	232	0	397	232	633	363	0	932	518	0	1,297	708	0	1,730	952	
	2	8	86	61	122	14	183	122	206	15	497	206	497	314	22	715	445	26	975	615	33	1,276	813	
	5	20	82	NA	NA	27	177	119	200	35	312	200	487	308	55	702	438	65	960	605	77	1,259	798	
	10	26	76	NA	NA	35	168	114	190	45	299	190	56	471	73	681	426	86	935	589	101	1,230	773	
	15	59	70	NA	NA	42	158	NA	180	66	287	180	66	455	288	85	662	413	100	911	572	117	1,203	747
100	20	NA	NA	NA	NA	50	149	NA	NA	63	275	169	76	440	278	97	642	401	113	888	556	131	1,176	722
	30	NA	NA	NA	NA	69	131	NA	NA	84	250	NA	99	410	259	123	605	376	141	844	522	161	1,125	670
	0	NA	NA	NA	NA	0	218	NA	NA	0	407	NA	0	665	400	0	997	560	0	1,411	770	0	1,908	1,040
	2	NA	NA	NA	NA	10	194	NA	NA	12	354	NA	13	566	375	18	831	510	21	1,155	700	25	1,536	935
	5	NA	NA	NA	NA	26	189	NA	NA	33	347	NA	40	557	369	52	820	504	60	1,141	692	71	1,519	926
	10	NA	NA	NA	NA	33	182	NA	NA	43	335	NA	53	542	361	68	801	493	80	1,118	679	94	1,492	910
100	15	NA	NA	NA	NA	40	174	NA	NA	50	321	NA	62	528	353	80	782	482	93	1,095	666	109	1,465	895
	20	NA	NA	NA	NA	47	166	NA	NA	59	311	NA	71	513	344	90	763	471	105	1,073	653	122	1,438	880
	30	NA	NA	NA	NA	NA	NA	NA	NA	78	290	NA	92	483	NA	115	726	449	131	1,029	627	149	1,387	849
	50	NA	NA	NA	NA	NA	NA	NA	NA	NA	NA	NA	147	428	NA	180	651	405	197	944	575	217	1,288	787

(continued)

Number of Appliances	Single
Appliance Type	Category I
Appliance Vent Connection	Connected directly to vent

TABLE 504.2(1)—continued  
TYPE B DOUBLE-WALL GAS VENT

HEIGHT (H) (feet)		VENT DIAMETER—(D) inches																																																
		10						12						14						16						18						20						22						24						
		LATERAL (L) (feet)		FAN		NAT		FAN		NAT		FAN		NAT		FAN		NAT		FAN		NAT		FAN		NAT		FAN		NAT		FAN		NAT		FAN		NAT		FAN		NAT		FAN		NAT				
Min	Max	Min	Max	Min	Max	Min	Max	Min	Max	Min	Max	Min	Max	Min	Max	Min	Max	Min	Max	Min	Max	Min	Max	Min	Max	Min	Max	Min	Max	Min	Max	Min	Max	Min	Max	Min	Max	Min	Max	Min	Max	Min	Max							
6	0	0	1,121	570	0	1,645	850	0	2,267	1,170	0	2,983	1,530	0	3,802	1,960	0	4,721	2,430	0	5,737	2,950	0	6,853	3,520	2	75	675	455	103	982	650	138	1,346	890	178	1,769	1,170	225	2,250	1,480	296	2,782	1,850	360	3,377	2,220	426	4,030	2,670
	4	110	668	445	147	975	640	191	1,338	880	242	1,761	1,160	300	2,242	1,475	390	2,774	1,835	469	3,370	2,215	555	4,023	2,660	6	128	661	435	171	967	630	219	1,330	870	276	1,753	1,150	341	2,235	1,470	437	2,767	1,820	523	3,363	2,210	618	4,017	2,650
	0	0	1,261	660	0	1,858	970	0	2,571	1,320	0	3,399	1,740	0	4,333	2,220	0	5,387	2,750	0	6,555	3,360	0	7,838	4,010	2	71	770	515	98	1,124	745	130	1,543	1,020	168	2,030	1,340	212	2,584	1,700	278	3,196	2,110	336	3,882	2,560	401	4,634	3,050
	5	115	758	503	154	1,110	733	199	1,528	1,010	251	2,013	1,330	311	2,563	1,685	398	3,180	2,090	476	3,863	2,545	562	4,612	3,040	8	137	746	490	180	1,097	720	231	1,514	1,000	289	2,000	1,320	354	2,552	1,670	450	3,163	2,070	537	3,850	2,530	630	4,602	3,030
10	0	0	1,377	720	0	2,036	1,060	0	2,825	1,450	0	3,742	1,925	0	4,782	2,450	0	5,955	3,050	0	7,254	3,710	0	8,682	4,450	2	68	852	560	93	1,244	850	124	1,713	1,130	161	2,256	1,480	202	2,868	1,890	264	3,556	2,340	319	4,322	2,840	378	5,153	3,390
	5	112	839	547	149	1,229	829	192	1,696	1,105	243	2,238	1,461	300	2,849	1,871	382	3,536	2,318	458	4,301	2,818	540	5,132	3,371	10	142	817	525	187	1,204	795	238	1,669	1,080	298	2,209	1,430	364	2,818	1,840	459	3,504	2,280	546	4,268	2,780	641	5,099	3,340
	0	0	1,596	840	0	2,380	1,240	0	3,323	1,720	0	4,423	2,270	0	5,678	2,900	0	7,099	3,620	0	8,665	4,410	0	10,393	5,300	2	63	1,019	675	86	1,495	985	114	2,062	1,350	147	2,719	1,770	186	3,467	2,260	239	4,304	2,800	290	5,232	3,410	346	6,251	4,080
	5	105	1,003	660	140	1,476	967	182	2,041	1,327	229	2,696	1,748	283	3,442	2,235	355	4,278	2,777	426	5,204	3,385	501	6,222	4,057	10	135	977	635	177	1,446	936	227	2,009	1,289	283	2,659	1,712	346	3,402	2,193	432	4,234	2,739	510	5,159	3,343	599	6,175	4,019
15	15	155	953	610	202	1,418	905	257	1,976	1,250	318	2,623	1,675	385	3,363	2,150	479	4,192	2,700	564	5,115	3,300	665	6,129	3,980	0	0	1,756	930	0	2,637	1,350	0	3,701	1,900	0	4,948	2,520	0	6,376	3,250	0	7,988	4,060	0	9,785	4,980	0	11,753	6,000
	2	59	1,150	755	81	1,694	1,100	107	2,343	1,520	139	3,097	2,000	175	3,955	2,570	220	4,916	3,200	269	5,983	3,910	321	7,154	4,700	5	101	1,133	738	135	1,674	1,079	174	2,320	1,498	219	3,071	1,978	270	3,926	2,544	337	4,885	3,174	403	5,950	3,880	475	7,119	4,662
	10	130	1,105	710	172	1,641	1,045	220	2,282	1,460	273	3,029	1,940	334	3,880	2,500	413	4,835	3,130	489	5,896	3,830	573	7,063	4,600	15	150	1,078	688	195	1,609	1,018	248	2,245	1,425	306	2,988	1,910	372	3,835	2,465	459	4,786	3,090	541	5,844	3,795	631	7,007	4,575
	20	167	1,052	665	217	1,578	990	273	2,210	1,390	335	2,948	1,880	404	3,791	2,430	495	4,737	3,050	585	5,792	3,760	689	6,953	4,550																									

(continued)



Number of Appliances	Single
Appliance Type	Category I
Appliance Vent Connection	Connected directly to vent

TABLE 504.2(1)—continued  
TYPE B DOUBLE-WALL GAS VENT

		VENT DIAMETER—(D) inches																							
		10			12			14			16			18			20			22			24		
HEIGHT (H) (feet)	LATERAL (L) (feet)	APPLIANCE INPUT RATING IN THOUSANDS OF BTU/H																							
		FAN		NAT		FAN		NAT		FAN		NAT		FAN		NAT		FAN		NAT		FAN		NAT	
		Min	Max	Min	Max	Min	Max	Min	Max	Min	Max	Min	Max	Min	Max	Min	Max	Min	Max	Min	Max	Min	Max	Min	Max
30	0	0	1,977	1,060	0	3,004	1,550	0	4,252	2,170	0	5,725	2,920	0	7,420	3,770	0	9,341	4,750	0	11,483	5,850	0	13,848	7,060
	2	54	1,351	865	74	2,004	1,310	98	2,786	1,800	127	3,696	2,380	159	4,734	3,050	199	5,900	3,810	241	7,194	4,650	285	8,617	5,600
	5	96	1,332	851	127	1,981	1,289	164	2,759	1,775	206	3,666	2,350	252	4,701	3,020	312	5,863	3,783	373	7,155	4,622	439	8,574	5,552
	10	125	1,301	829	164	1,944	1,254	209	2,716	1,733	259	3,617	2,300	316	4,647	2,970	386	5,803	3,739	456	7,090	4,574	535	8,505	5,471
	15	143	1,272	807	187	1,908	1,220	237	2,674	1,692	292	3,570	2,250	354	4,594	2,920	431	5,744	3,695	507	7,026	4,527	590	8,437	5,391
	20	160	1,243	784	207	1,873	1,185	260	2,633	1,650	319	3,523	2,200	384	4,542	2,870	467	5,686	3,650	548	6,964	4,480	639	8,370	5,310
	30	195	1,189	745	246	1,807	1,130	305	2,555	1,585	369	3,433	2,130	440	4,442	2,785	540	5,574	3,565	635	6,842	4,375	739	8,239	5,225
	0	0	2,231	1,195	0	3,441	1,825	0	4,934	2,550	0	6,711	3,440	0	8,774	4,460	0	11,129	5,635	0	13,767	6,940	0	16,694	8,430
	2	41	1,620	1,010	66	2,431	1,513	86	3,409	2,125	113	4,554	2,840	141	5,864	3,670	171	7,339	4,630	209	8,980	5,695	251	10,788	6,860
	5	90	1,600	996	118	2,406	1,495	151	3,380	2,102	191	4,520	2,813	234	5,826	3,639	283	7,295	4,597	336	8,933	5,654	394	10,737	6,818
50	10	118	1,567	972	154	2,366	1,466	196	3,332	2,064	243	4,464	2,767	295	5,763	3,585	355	7,224	4,542	419	8,855	5,585	491	10,652	6,749
	15	136	1,536	948	177	2,327	1,437	222	3,285	2,026	274	4,409	2,721	330	5,701	3,534	396	7,155	4,511	465	8,779	5,546	542	10,570	6,710
	20	151	1,505	924	195	2,288	1,408	244	3,239	1,987	300	4,356	2,675	361	5,641	3,481	433	7,086	4,479	506	8,704	5,506	586	10,488	6,670
	30	183	1,446	876	232	2,214	1,349	287	3,150	1,910	347	4,253	2,631	412	5,523	3,431	494	6,953	4,421	577	8,557	5,444	672	10,328	6,603
	0	0	2,491	1,310	0	3,925	2,050	0	5,729	2,950	0	7,914	4,050	0	10,485	5,300	0	13,454	6,700	0	16,817	8,600	0	20,578	10,300
	2	30	1,975	1,170	44	3,027	1,820	72	4,313	2,550	95	5,834	3,500	120	7,591	4,600	138	9,577	5,800	169	11,803	7,200	204	14,264	8,800
	5	82	1,955	1,159	107	3,002	1,803	136	4,282	2,531	172	5,797	3,475	208	7,548	4,566	245	9,528	5,769	293	11,748	7,162	341	14,204	8,756
	10	108	1,923	1,142	142	2,961	1,775	180	4,231	2,500	223	5,737	3,434	268	7,478	4,509	318	9,447	5,717	374	11,658	7,100	436	14,105	8,683
	15	126	1,892	1,124	163	2,920	1,747	206	4,182	2,469	252	5,678	3,392	304	7,409	4,451	358	9,367	5,665	418	11,569	7,037	487	14,007	8,610
	20	141	1,861	1,107	181	2,880	1,719	226	4,133	2,438	277	5,619	3,351	330	7,341	4,394	387	9,289	5,613	452	11,482	6,975	523	13,910	8,537
30	170	1,802	1,071	215	2,803	1,663	265	4,037	2,375	319	5,505	3,267	378	7,209	4,279	446	9,136	5,509	514	11,310	6,850	592	13,720	8,391	
50	241	1,688	1,000	292	2,657	1,550	350	3,856	2,250	415	5,289	3,100	486	6,956	4,050	572	8,841	5,300	659	10,979	6,600	752	13,354	8,100	

For SI: 1 inch = 25.4 mm, 1 foot = 304.8 mm, 1 British thermal unit per hour = 0.2931 W.

Number of Appliances	Single
Appliance Type	Category I
Appliance Vent Connection	Single-wall metal connector

TABLE 504.2(2)  
TYPE B DOUBLE-WALL GAS VENT

HEIGHT LATERAL (H) (feet)	LATERAL (L) (feet)	VENT DIAMETER—(D) inches																												
		3			4			5			6			7			8			9			10			12				
		FAN		NAT	FAN		NAT	FAN		NAT	FAN		NAT	FAN		NAT	FAN		NAT	FAN		NAT	FAN		NAT	FAN		NAT	FAN	
Min		Max	Min	Max	Min	Max	Min	Max	Min	Max	Min	Max	Min	Max	Min	Max	Min	Max	Min	Max	Min	Max	Min	Max	Min	Max	Min	Max	Min	Max
6	0	38	77	45	59	151	85	85	249	140	126	373	204	165	522	284	211	695	369	267	894	469	371	1,118	569	537	1,639	849	648	
	2	39	51	36	60	96	66	85	156	104	123	231	156	159	320	213	201	423	284	251	541	368	347	673	453	498	979	648		
	4	NA	NA	33	74	92	63	102	152	102	146	225	152	187	313	208	237	416	277	295	533	360	409	664	443	584	971	638		
	6	NA	NA	31	83	89	60	114	147	99	163	220	148	207	307	203	263	409	271	327	526	352	449	656	433	638	962	627		
8	0	37	83	50	58	164	93	83	273	154	123	412	234	161	580	319	206	777	414	258	1,002	536	360	1,257	658	521	1,852	967		
	2	39	56	39	59	108	75	83	176	119	121	261	179	155	363	246	197	482	321	246	617	417	339	768	513	486	1,120	743		
	5	NA	NA	37	77	102	69	107	168	114	151	252	171	193	352	235	245	470	311	305	604	404	418	754	500	598	1,104	730		
	8	NA	NA	33	90	95	64	122	161	107	175	243	163	223	342	225	280	458	300	344	591	392	470	740	486	665	1,089	715		
10	0	37	87	53	57	174	99	82	293	165	120	444	254	158	628	344	202	844	449	253	1,093	584	351	1,373	718	507	2,031	1,057		
	2	39	61	41	59	117	80	82	193	128	119	287	194	153	400	272	193	531	354	242	681	456	332	849	559	475	1,242	848		
	5	52	56	39	76	111	76	105	185	122	148	277	186	190	388	261	241	518	344	299	667	443	409	834	544	584	1,224	825		
	10	NA	NA	34	97	100	68	132	171	112	188	261	171	237	369	241	296	497	325	363	643	423	492	808	520	688	1,194	788		
15	0	36	93	57	56	190	111	80	325	186	116	499	283	153	713	388	195	966	523	244	1,259	681	336	1,591	838	488	2,374	1,237		
	2	38	69	47	57	136	93	80	225	149	115	337	224	148	473	314	187	631	413	232	812	543	319	1,015	673	457	1,491	983		
	5	51	63	44	75	128	86	102	216	140	144	326	217	182	459	298	231	616	400	287	795	526	392	997	657	562	1,469	963		
	10	NA	NA	39	95	116	79	128	201	131	182	308	203	228	438	284	284	592	381	349	768	501	470	966	628	664	1,433	928		
20	15	NA	NA	NA	NA	NA	72	158	186	124	220	290	192	272	418	269	334	568	367	404	742	484	540	937	601	750	1,399	894		
	0	35	96	60	54	200	118	78	346	201	114	537	306	149	772	428	190	1,053	573	238	1,379	750	326	1,751	927	473	2,631	1,346		
	2	37	74	50	56	148	99	78	248	165	113	375	248	144	528	344	182	708	468	227	914	611	309	1,146	754	443	1,689	1,098		
	5	50	68	47	73	140	94	100	239	158	141	363	239	178	514	334	224	692	457	279	896	596	381	1,126	734	547	1,665	1,074		
20	10	NA	NA	41	93	129	86	125	223	146	177	344	224	222	491	316	277	666	437	339	866	570	457	1,092	702	646	1,626	1,037		
	15	NA	NA	NA	NA	NA	80	155	208	136	216	325	210	264	469	301	325	640	419	393	838	549	526	1,060	677	730	1,587	1,005		
	20	NA	NA	NA	NA	NA	NA	186	192	126	254	306	196	309	448	285	374	616	400	448	810	526	592	1,028	651	808	1,550	973		

(continued)

Number of Appliances	Single
Appliance Type	Category I
Appliance Vent Connection	Single-wall metal connector

TABLE 504.2(2)—continued  
TYPE B DOUBLE-WALL GAS VENT

HEIGHT/LATERAL (H) (L) (feet)	VENT DIAMETER—(D) inches																																	
	3			4			5			6			7			8			9			10			12									
	FAN		NAT	FAN		NAT	FAN		NAT	FAN		NAT	FAN		NAT	FAN		NAT	FAN		NAT	FAN		NAT	FAN		NAT							
Min		Max	Min	Max	Min	Max	Min	Max	Min	Max	Min	Max	Min	Max	Min	Max	Min	Max	Min	Max	Min	Max	Min	Max	Min	Max	Min	Max						
30	0	34	99	63	53	211	127	110	584	334	144	849	472	184	1,168	647	229	1,542	852	312	1,971	1,056	454	2,996	1,545									
	2	37	80	56	55	164	111	76	281	183	109	429	279	139	610	392	175	1,069	698	296	1,346	863	424	1,999	1,308									
	5	49	74	52	72	157	106	98	271	173	136	417	271	171	595	382	215	1,049	684	366	1,324	846	524	1,971	1,283									
	10	NA	NA	NA	91	144	98	122	255	168	171	397	257	213	570	367	265	777	501	327	1,017	662	440	1,287	821	620	1,927	1,234						
	15	NA	NA	NA	115	131	NA	151	239	157	208	377	242	255	547	349	312	750	481	379	985	638	507	1,251	794	702	1,884	1,205						
	20	NA	NA	NA	NA	NA	NA	181	223	NA	246	357	228	298	524	333	360	723	461	433	955	615	570	1,216	768	780	1,841	1,166						
	30	NA	NA	NA	NA	NA	NA	NA	NA	NA	NA	NA	389	477	305	461	670	426	541	895	574	704	1,147	720	937	1,759	1,101							
	0	33	99	66	51	213	133	73	394	230	105	629	361	138	928	515	176	1,292	704	220	1,724	948	295	2,223	1,189	428	3,432	1,818						
	2	36	84	61	53	181	121	73	318	205	104	495	312	133	712	443	168	971	613	209	1,273	811	280	1,615	1,007	401	2,426	1,509						
	5	48	80	NA	70	174	117	94	308	198	131	482	305	164	696	435	204	953	602	257	1,252	795	347	1,591	991	496	2,396	1,490						
10	NA	NA	NA	89	160	NA	118	292	186	162	461	292	203	671	420	253	923	583	313	1,217	765	418	1,551	963	589	2,347	1,455							
15	NA	NA	NA	112	148	NA	145	275	174	199	441	280	244	646	405	299	894	562	363	1,183	736	481	1,512	934	668	2,299	1,421							
20	NA	NA	NA	NA	NA	NA	176	257	NA	236	420	267	285	622	389	345	866	543	415	1,150	708	544	1,473	906	741	2,251	1,387							
30	NA	NA	NA	NA	NA	NA	NA	NA	NA	315	376	NA	373	573	NA	442	809	502	521	1,086	649	674	1,399	848	892	2,159	1,318							
0	NA	NA	NA	49	214	NA	69	403	NA	100	659	395	131	991	555	166	1,404	765	207	1,900	1,033	273	2,479	1,300	395	3,912	2,042							
2	NA	NA	NA	51	192	NA	70	351	NA	98	563	373	125	828	508	158	1,152	698	196	1,532	933	259	1,970	1,168	371	3,021	1,817							
5	NA	NA	NA	67	186	NA	90	342	NA	125	551	366	156	813	501	194	1,134	688	240	1,511	921	322	1,945	1,153	460	2,990	1,796							
10	NA	NA	NA	85	175	NA	113	324	NA	153	532	354	191	789	486	238	1,104	672	293	1,477	902	389	1,905	1,133	547	2,938	1,763							
15	NA	NA	NA	132	162	NA	138	310	NA	188	511	343	230	764	473	281	1,075	656	342	1,443	884	447	1,865	1,110	618	2,888	1,730							
20	NA	NA	NA	NA	NA	NA	168	295	NA	224	487	NA	270	739	458	325	1,046	639	391	1,410	864	507	1,825	1,087	690	2,838	1,696							
30	NA	NA	NA	NA	NA	NA	231	264	NA	301	448	NA	355	685	NA	418	988	NA	491	1,343	824	631	1,747	1,041	834	2,739	1,627							
50	NA	NA	NA	NA	NA	NA	NA	NA	NA	NA	NA	NA	540	584	NA	617	866	NA	711	1,205	NA	895	1,591	NA	1,138	2,547	1,489							

For SI: 1 inch = 25.4 mm, 1 foot = 304.8 mm, 1 British thermal unit per hour = 0.2931 W.

TABLE 504.2(3)  
MASONRY CHIMNEY

Number of Appliances	Single
Appliance Type	Category I
Appliance Vent Connection	Type B double-wall connector

HEIGHT (H) (feet)	LATERAL (L) (feet)	TYPE B DOUBLE-WALL CONNECTOR DIAMETER—(D) inches to be used with chimney areas within the size limits at bottom																												
		3			4			5			6			7			8			9			10			12				
		FAN		NAT	FAN		NAT	FAN		NAT	FAN		NAT	FAN		NAT	FAN		NAT	FAN		NAT	FAN		NAT	FAN		NAT	FAN	
Min		Max	Min	Max	Min	Max	Min	Max	Min	Max	Min	Max	Min	Max	Min	Max	Min	Max	Min	Max	Min	Max	Min	Max	Min	Max	Min	Max	Min	Max
6	2	NA	NA	28	NA	NA	52	NA	NA	86	NA	NA	130	NA	NA	180	NA	NA	247	NA	NA	320	NA	NA	401	NA	NA	581		
	5	NA	NA	25	NA	NA	49	NA	NA	82	NA	NA	117	NA	NA	165	NA	NA	231	NA	NA	298	NA	NA	376	NA	NA	561		
	2	NA	NA	29	NA	NA	55	NA	NA	93	NA	NA	145	NA	NA	198	NA	NA	266	84	590	350	100	728	446	139	1,024	651		
8	5	NA	NA	26	NA	NA	52	NA	NA	88	NA	NA	134	NA	NA	183	NA	NA	247	NA	NA	328	149	711	423	201	1,007	640		
	8	NA	NA	24	NA	NA	48	NA	NA	83	NA	NA	127	NA	NA	175	NA	NA	239	NA	NA	318	173	695	410	231	990	623		
	2	NA	NA	31	NA	NA	61	NA	NA	103	NA	NA	162	NA	NA	221	68	519	298	82	655	388	98	810	491	136	1,144	724		
10	5	NA	NA	28	NA	NA	57	NA	NA	96	NA	NA	148	NA	NA	204	NA	NA	277	124	638	365	146	791	466	196	1,124	712		
	10	NA	NA	25	NA	NA	50	NA	NA	87	NA	NA	139	NA	NA	191	NA	NA	263	155	610	347	182	762	444	240	1,093	668		
	2	NA	NA	35	NA	NA	67	NA	NA	114	NA	NA	179	53	475	250	64	613	336	77	779	441	92	968	562	127	1,376	841		
15	5	NA	NA	35	NA	NA	62	NA	NA	107	NA	NA	164	NA	NA	231	99	594	313	118	759	416	139	946	533	186	1,352	828		
	10	NA	NA	28	NA	NA	55	NA	NA	97	NA	NA	153	NA	NA	216	126	565	296	148	727	394	173	912	567	229	1,315	777		
	15	NA	NA	NA	NA	NA	48	NA	NA	89	NA	NA	141	NA	NA	201	NA	NA	281	171	698	375	198	880	485	259	1,280	742		
20	2	NA	NA	38	NA	NA	74	NA	NA	124	NA	NA	201	51	522	274	61	678	375	73	867	491	87	1,083	627	121	1,548	953		
	5	NA	NA	36	NA	NA	68	NA	NA	116	NA	NA	184	80	503	254	95	658	350	113	845	463	133	1,059	597	179	1,523	933		
	10	NA	NA	NA	NA	NA	60	NA	NA	107	NA	NA	172	NA	NA	237	122	627	332	143	811	440	167	1,022	566	221	1,482	879		
20	15	NA	NA	NA	NA	NA	NA	NA	NA	97	NA	NA	159	NA	NA	220	NA	NA	314	165	780	418	191	987	541	251	1,443	840		
	20	NA	NA	NA	NA	NA	NA	NA	NA	83	NA	NA	148	NA	NA	206	NA	NA	296	186	750	397	214	955	513	277	1,406	807		

(continued)

Number of Appliances	Single
Appliance Type	Category I
Appliance Vent Connection	Type B double-wall connector

TABLE 504.2(3)—continued  
MASONRY CHIMNEY

HEIGHT (H) (feet)	LATERAL (L) (feet)	TYPE B DOUBLE-WALL CONNECTOR DIAMETER—(D) inches to be used with chimney areas within the size limits at bottom																							
		APPLIANCE INPUT RATING IN THOUSANDS OF BTU/H																							
		3		4		5		6		7		8		9		10		12							
30	2	FAN	NAT	FAN	NAT	FAN	NAT	FAN	NAT	FAN	NAT	FAN	NAT	FAN	NAT	FAN	NAT	FAN	NAT	FAN	NAT	FAN	NAT		
		Min	Max	Min	Max	Min	Max	Min	Max	Min	Max	Min	Max	Min	Max	Min	Max	Min	Max	Min	Max	Min	Max		
		NA	NA	NA	NA	NA	NA	NA	NA	NA	NA	NA	NA	NA	NA	NA	NA	NA	NA	NA	NA	NA	NA		
		NA	41	NA	82	NA	137	NA	216	47	581	303	762	421	68	985	558	81	1,240	717	111	1,793	1,112		
		NA	NA	NA	NA	NA	128	NA	198	75	561	281	90	741	393	106	962	526	125	1,216	683	169	1,766	1,094	
		NA	NA	NA	NA	NA	115	NA	184	NA	NA	263	115	709	373	135	927	500	158	1,176	648	210	1,721	1,025	
	15	NA	NA	NA	NA	107	NA	171	NA	NA	243	NA	NA	353	156	893	476	181	1,139	621	239	1,679	981		
		NA	NA	NA	NA	91	NA	159	NA	NA	227	NA	NA	332	176	860	450	203	1,103	592	264	1,638	940		
		NA	NA	NA	NA	NA	NA	NA	NA	NA	188	NA	NA	288	NA	NA	416	249	1,035	555	318	1,560	877		
		NA	NA	NA	NA	NA	161	NA	251	NA	NA	351	51	840	477	61	1,106	633	72	1,413	812	99	2,080	1,243	
		NA	NA	NA	NA	NA	151	NA	230	NA	NA	323	83	819	445	98	1,083	596	116	1,387	774	155	2,052	1,225	
		NA	NA	NA	NA	NA	138	NA	215	NA	NA	304	NA	NA	424	126	1,047	567	147	1,347	733	195	2,006	1,147	
50	15	NA	NA	NA	127	NA	199	NA	NA	282	NA	NA	400	146	1,010	539	170	1,307	702	222	1,961	1,099			
	20	NA	NA	NA	NA	NA	185	NA	NA	264	NA	NA	376	165	977	511	190	1,269	669	246	1,916	1,050			
	NA	NA	NA	NA	NA	NA	NA	NA	NA	NA	NA	NA	NA	NA	NA	NA	233	1,196	623	295	1,832	984			
	12	19	28	38	50	63	78	95	132																
	49	88	137	198	269	352	445	550	792																
	Minimum Internal Area of Chimney (square inches)	12	19	28	38	50	63	78	95	132															
Maximum Internal Area of Chimney (square inches)	49	88	137	198	269	352	445	550	792																

For SI: 1 inch = 25.4 mm, 1 square inch = 645.16 mm<sup>2</sup>, 1 foot = 304.8 mm, 1 British thermal unit per hour = 0.2931 W.

TABLE 504.2(4)  
MASONRY CHIMNEY

Number of Appliances	Single
Appliance Type	Category I
Appliance Vent Connection	Single-wall metal connector

HEIGHT (H) (feet)	LATERAL (L) (feet)	SINGLE-WALL METAL CONNECTOR DIAMETER—(D) inches to be used with chimney areas within the size limits at bottom																													
		APPLIANCE INPUT RATING IN THOUSANDS OF BTU/H																													
		3		4		5		6		7		8		9		10		12													
FAN		FAN		FAN		FAN		FAN		FAN		FAN		FAN		FAN		FAN		NAT		NAT		NAT		NAT					
Min		Max		Min		Max		Min		Max		Min		Max		Min		Max		Min		Max		Min		Max		Min		Max	
6	2	NA	NA	28	NA	NA	52	NA	NA	86	NA	NA	130	NA	NA	180	NA	NA	247	NA	NA	319	NA	NA	400	NA	NA	580			
	5	NA	NA	25	NA	NA	48	NA	NA	81	NA	NA	116	NA	NA	164	NA	NA	230	NA	NA	297	NA	NA	375	NA	NA	560			
	2	NA	NA	29	NA	NA	55	NA	NA	93	NA	NA	145	NA	NA	197	NA	NA	265	NA	NA	349	382	725	445	549	1,021	650			
8	5	NA	NA	26	NA	NA	51	NA	NA	87	NA	NA	133	NA	NA	182	NA	NA	246	NA	NA	327	NA	NA	422	673	1,003	638			
	8	NA	NA	23	NA	NA	47	NA	NA	82	NA	NA	126	NA	NA	174	NA	NA	237	NA	NA	317	NA	NA	408	747	985	621			
	2	NA	NA	31	NA	NA	61	NA	NA	102	NA	NA	161	NA	NA	220	216	518	297	271	654	387	373	808	490	536	1,142	722			
10	5	NA	NA	28	NA	NA	56	NA	NA	95	NA	NA	147	NA	NA	203	NA	NA	276	334	635	364	459	789	465	657	1,121	710			
	10	NA	NA	24	NA	NA	49	NA	NA	86	NA	NA	137	NA	NA	189	NA	NA	261	NA	NA	345	547	758	441	771	1,088	665			
	2	NA	NA	35	NA	NA	67	NA	NA	113	NA	NA	178	166	473	249	211	611	335	264	776	440	362	965	560	520	1,373	840			
15	5	NA	NA	32	NA	NA	61	NA	NA	106	NA	NA	163	NA	NA	230	261	591	312	325	775	414	444	942	531	637	1,348	825			
	10	NA	NA	27	NA	NA	54	NA	NA	96	NA	NA	151	NA	NA	214	NA	NA	294	392	722	392	531	907	504	749	1,309	774			
	15	NA	NA	NA	NA	NA	46	NA	NA	87	NA	NA	138	NA	NA	198	NA	NA	278	452	692	372	606	873	481	841	1,272	738			
20	2	NA	NA	38	NA	NA	73	NA	NA	123	NA	NA	200	163	520	273	206	675	374	258	864	490	252	1,079	625	508	1,544	950			
	5	NA	NA	35	NA	NA	67	NA	NA	115	NA	NA	183	80	NA	252	255	655	348	317	842	461	433	1,055	594	623	1,518	930			
	10	NA	NA	NA	NA	NA	59	NA	NA	105	NA	NA	170	NA	NA	235	312	622	330	382	806	437	517	1,016	562	733	1,475	875			
20	15	NA	NA	NA	NA	NA	NA	NA	NA	95	NA	NA	156	NA	NA	217	NA	NA	311	442	773	414	591	979	539	823	1,434	835			
	20	NA	NA	NA	NA	NA	NA	NA	NA	80	NA	NA	144	NA	NA	202	NA	NA	292	NA	NA	392	663	944	510	911	1,394	800			

(continued)

Number of Appliances	Single
Appliance Type	Category I
Appliance Vent Connection	Single-wall metal connector

TABLE 504.2(4)—continued  
MASONRY CHIMNEY

HEIGHT (H) (feet)	LATERAL (L) (feet)	SINGLE-WALL METAL CONNECTOR DIAMETER—(D) inches to be used with chimney areas within the size limits at bottom																																						
		APPLIANCE INPUT RATING IN THOUSANDS OF BTU/H																																						
		3		4		5		6		7		8		9		10		12																						
		FAN	NAT	FAN	NAT	FAN	NAT	FAN	NAT	FAN	NAT	FAN	NAT	FAN	NAT	FAN	NAT	FAN	NAT	FAN	NAT	FAN	NAT	FAN	NAT	FAN	NAT	FAN	NAT	FAN	NAT	FAN	NAT	FAN	NAT					
		Min	Max	Min	Max	Min	Max	Min	Max	Min	Max	Min	Max	Min	Max	Min	Max	Min	Max	Min	Max	Min	Max	Min	Max	Min	Max	Min	Max	Min	Max	Min	Max	Min	Max	Min	Max			
	2	NA	NA	NA	NA	NA	NA	NA	NA	NA	NA	NA	NA	NA	NA	NA	NA	NA	NA	NA	NA	NA	NA	NA	NA	NA	NA	NA	NA	NA	NA	NA	NA	NA	NA	NA	NA	NA	NA	
	5	NA	NA	NA	NA	NA	NA	NA	NA	NA	NA	NA	NA	NA	NA	NA	NA	NA	NA	NA	NA	NA	NA	NA	NA	NA	NA	NA	NA	NA	NA	NA	NA	NA	NA	NA	NA	NA	NA	NA
	10	NA	NA	NA	NA	NA	NA	NA	NA	NA	NA	NA	NA	NA	NA	NA	NA	NA	NA	NA	NA	NA	NA	NA	NA	NA	NA	NA	NA	NA	NA	NA	NA	NA	NA	NA	NA	NA	NA	NA
	15	NA	NA	NA	NA	NA	NA	NA	NA	NA	NA	NA	NA	NA	NA	NA	NA	NA	NA	NA	NA	NA	NA	NA	NA	NA	NA	NA	NA	NA	NA	NA	NA	NA	NA	NA	NA	NA	NA	NA
	20	NA	NA	NA	NA	NA	NA	NA	NA	NA	NA	NA	NA	NA	NA	NA	NA	NA	NA	NA	NA	NA	NA	NA	NA	NA	NA	NA	NA	NA	NA	NA	NA	NA	NA	NA	NA	NA	NA	NA
	30	NA	NA	NA	NA	NA	NA	NA	NA	NA	NA	NA	NA	NA	NA	NA	NA	NA	NA	NA	NA	NA	NA	NA	NA	NA	NA	NA	NA	NA	NA	NA	NA	NA	NA	NA	NA	NA	NA	NA
	2	NA	NA	NA	NA	NA	NA	NA	NA	NA	NA	NA	NA	NA	NA	NA	NA	NA	NA	NA	NA	NA	NA	NA	NA	NA	NA	NA	NA	NA	NA	NA	NA	NA	NA	NA	NA	NA	NA	NA
	5	NA	NA	NA	NA	NA	NA	NA	NA	NA	NA	NA	NA	NA	NA	NA	NA	NA	NA	NA	NA	NA	NA	NA	NA	NA	NA	NA	NA	NA	NA	NA	NA	NA	NA	NA	NA	NA	NA	NA
	10	NA	NA	NA	NA	NA	NA	NA	NA	NA	NA	NA	NA	NA	NA	NA	NA	NA	NA	NA	NA	NA	NA	NA	NA	NA	NA	NA	NA	NA	NA	NA	NA	NA	NA	NA	NA	NA	NA	NA
	15	NA	NA	NA	NA	NA	NA	NA	NA	NA	NA	NA	NA	NA	NA	NA	NA	NA	NA	NA	NA	NA	NA	NA	NA	NA	NA	NA	NA	NA	NA	NA	NA	NA	NA	NA	NA	NA	NA	NA
	20	NA	NA	NA	NA	NA	NA	NA	NA	NA	NA	NA	NA	NA	NA	NA	NA	NA	NA	NA	NA	NA	NA	NA	NA	NA	NA	NA	NA	NA	NA	NA	NA	NA	NA	NA	NA	NA	NA	NA
	30	NA	NA	NA	NA	NA	NA	NA	NA	NA	NA	NA	NA	NA	NA	NA	NA	NA	NA	NA	NA	NA	NA	NA	NA	NA	NA	NA	NA	NA	NA	NA	NA	NA	NA	NA	NA	NA	NA	NA
Minimum Internal Area of Chimney (square inches)	12			19		28		38		50		63		78		95		132																						
Maximum Internal Area of Chimney (square inches)	49	88		137		198		269		352		445		550		792																								

For SI: 1 inch = 25.4 mm, 1 square inch = 645.16 mm<sup>2</sup>, 1 foot = 304.8 mm, 1 British thermal unit per hour = 0.2931 W.

CHIMNEYS AND VENTS

**TABLE 504.2(5)  
SINGLE-WALL METAL PIPE OR TYPE B  
ASBESTOS CEMENT VENT**

<b>Number of Appliances</b>	Single
<b>Appliance Type</b>	Draft hood equipped
<b>Appliance Vent Connection</b>	Connected directly to pipe or vent

HEIGHT (H) (feet)	LATERAL (L) (feet)	VENT DIAMETER—(D) inches							
		3	4	5	6	7	8	10	12
		MAXIMUM APPLIANCE INPUT RATING IN THOUSANDS OF BTU/H							
6	0	39	70	116	170	232	312	500	750
	2	31	55	94	141	194	260	415	620
	5	28	51	88	128	177	242	390	600
8	0	42	76	126	185	252	340	542	815
	2	32	61	102	154	210	284	451	680
	5	29	56	95	141	194	264	430	648
	10	24	49	86	131	180	250	406	625
10	0	45	84	138	202	279	372	606	912
	2	35	67	111	168	233	311	505	760
	5	32	61	104	153	215	289	480	724
	10	27	54	94	143	200	274	455	700
	15	NA	46	84	130	186	258	432	666
15	0	49	91	151	223	312	420	684	1,040
	2	39	72	122	186	260	350	570	865
	5	35	67	110	170	240	325	540	825
	10	30	58	103	158	223	308	514	795
	15	NA	50	93	144	207	291	488	760
	20	NA	NA	82	132	195	273	466	726
20	0	53	101	163	252	342	470	770	1,190
	2	42	80	136	210	286	392	641	990
	5	38	74	123	192	264	364	610	945
	10	32	65	115	178	246	345	571	910
	15	NA	55	104	163	228	326	550	870
	20	NA	NA	91	149	214	306	525	832
30	0	56	108	183	276	384	529	878	1,370
	2	44	84	148	230	320	441	730	1,140
	5	NA	78	137	210	296	410	694	1,080
	10	NA	68	125	196	274	388	656	1,050
	15	NA	NA	113	177	258	366	625	1,000
	20	NA	NA	99	163	240	344	596	960
	30	NA	NA	NA	NA	192	295	540	890
50	0	NA	120	210	310	443	590	980	1,550
	2	NA	95	171	260	370	492	820	1,290
	5	NA	NA	159	234	342	474	780	1,230
	10	NA	NA	146	221	318	456	730	1,190
	15	NA	NA	NA	200	292	407	705	1,130
	20	NA	NA	NA	185	276	384	670	1,080
	30	NA	NA	NA	NA	222	330	605	1,010

For SI: 1 inch = 25.4 mm, 1 foot = 304.8 mm, 1 British thermal unit per hour = 0.2931 W



**TABLE 504.2(6)  
EXTERIOR MASONRY CHIMNEY**

<b>Number of Appliances</b>	Single
<b>Appliance Type</b>	NAT
<b>Appliance Vent Connection</b>	Type B double-wall connector

MINIMUM ALLOWABLE INPUT RATING OF SPACE-HEATING APPLIANCE IN THOUSANDS OF BTU PER HOUR								
VENT HEIGHT (feet)	Internal area of chimney (square inches)							
	12	19	28	38	50	63	78	113
37°F or Greater Local 99% Winter Design Temperature: 37°F or Greater								
6	0	0	0	0	0	0	0	0
8	0	0	0	0	0	0	0	0
10	0	0	0	0	0	0	0	0
15	NA	0	0	0	0	0	0	0
20	NA	NA	123	190	249	184	0	0
30	NA	NA	NA	NA	NA	393	334	0
50	NA	NA	NA	NA	NA	NA	NA	579
27 to 36°F Local 99% Winter Design Temperature: 27 to 36°F								
6	0	0	68	116	156	180	212	266
8	0	0	82	127	167	187	214	263
10	0	51	97	141	183	201	225	265
15	NA	NA	NA	NA	233	253	274	305
20	NA	NA	NA	NA	NA	307	330	362
30	NA	NA	NA	NA	NA	419	445	485
50	NA	NA	NA	NA	NA	NA	NA	763
17 to 26°F Local 99% Winter Design Temperature: 17 to 26°F								
6	NA	NA	NA	NA	NA	215	259	349
8	NA	NA	NA	NA	197	226	264	352
10	NA	NA	NA	NA	214	245	278	358
15	NA	NA	NA	NA	NA	296	331	398
20	NA	NA	NA	NA	NA	352	387	457
30	NA	NA	NA	NA	NA	NA	507	581
50	NA	NA	NA	NA	NA	NA	NA	NA
5 to 16°F Local 99% Winter Design Temperature: 5 to 16°F								
6	NA	NA	NA	NA	NA	NA	NA	416
8	NA	NA	NA	NA	NA	NA	312	423
10	NA	NA	NA	NA	NA	289	331	430
15	NA	NA	NA	NA	NA	NA	393	485
20	NA	NA	NA	NA	NA	NA	450	547
30	NA	NA	NA	NA	NA	NA	NA	682
50	NA	NA	NA	NA	NA	NA	NA	972
-10 to 4°F Local 99% Winter Design Temperature: -10 to 4°F								
6	NA	NA	NA	NA	NA	NA	NA	484
8	NA	NA	NA	NA	NA	NA	NA	494
10	NA	NA	NA	NA	NA	NA	NA	513
15	NA	NA	NA	NA	NA	NA	NA	586
20	NA	NA	NA	NA	NA	NA	NA	650
30	NA	NA	NA	NA	NA	NA	NA	805
50	NA	NA	NA	NA	NA	NA	NA	1,003
-11°F or Lower Local 99% Winter Design Temperature: -11°F or Lower								
Not recommended for any vent configurations								

**Note:** See Figure B-19 in Appendix B for a map showing local 99 percent winter design temperatures in the United States.  
For SI: °C = [(°F - 32)/1.8, 1 inch = 25.4 mm, 1 foot = 304.8 mm, 1 British thermal unit per hour = 0.2931 W

**504.2.10 Corrugated vent connector size.** Corrugated vent connectors shall be not smaller than the listed appliance categorized vent diameter, flue collar diameter or draft hood outlet diameter.

**504.2.11 Vent connector size limitation.** Vent connectors shall not be increased in size more than two sizes greater than the listed appliance categorized vent diameter flue collar diameter or draft hood outlet diameter.

**504.2.12 Component commingling.** In a single run of vent or vent connector, different diameters and types of vent and connector components shall be permitted to be used, provided that all such sizes and types are permitted by the tables.

**504.2.13 Draft hood conversion accessories.** Draft hood conversion accessories for use with masonry chimneys venting listed Category I fan-assisted appliances shall be listed and installed in accordance with the manufacturer’s installation instructions for such listed accessories.

**504.2.14 Table interpolation.** Interpolation shall be permitted in calculating capacities for vent dimensions that fall between the table entries (see Example 3, Appendix B).

**504.2.15 Extrapolation prohibited.** Extrapolation beyond the table entries shall not be permitted.

**504.2.16 Engineering calculations.** For vent heights less than 6 feet (1829 mm) and greater than shown in the tables, engineering methods shall be used to calculate vent capacities.

**504.3 Application of multiple appliance vent Tables 504.3(1) through 504.3(7).** The application of Tables 504.3(1) through 504.3(7) shall be subject to the requirements of Sections 504.3.1 through 504.3.27.

**504.3.1 Vent obstructions.** These venting tables shall not be used where obstructions, as described in Section 503.15, are installed in the venting system. The installation of vents serving listed appliances with vent dampers shall be in accordance with the appliance manufacturer’s instructions or in accordance with the following:

1. The maximum capacity of the vent connector shall be determined using the NAT Max column.
2. The maximum capacity of the vertical vent or chimney shall be determined using the FAN+NAT column when the second appliance is a fan-assisted appliance, or the NAT+NAT column when the second appliance is equipped with a draft hood.
3. The minimum capacity shall be determined as if the appliance were a fan-assisted appliance.
  - 3.1. The minimum capacity of the vent connector shall be determined using the FAN Min column.
  - 3.2. The FAN+FAN column shall be used where the second appliance is a fan-assisted appliance, and the FAN+NAT column shall be used where the second appliance is equipped with a draft hood, to determine whether the vertical vent or chimney configuration is not permitted (NA). Where the vent configuration

is NA, the vent configuration shall not be permitted and an alternative venting configuration shall be utilized.

**504.3.2 Connector length limit.** The vent connector shall be routed to the vent utilizing the shortest possible route. Except as provided in Section 504.3.3, the maximum vent connector horizontal length shall be 1½ feet for each inch (457 mm per mm) of connector diameter as shown in Table 504.3.2.

**504.3.3 Connectors with longer lengths.** Connectors with longer horizontal lengths than those listed in Section 504.3.2 are permitted under the following conditions:

1. The maximum capacity (FAN Max or NAT Max) of the vent connector shall be reduced 10 percent for each additional multiple of the length allowed by Section 504.3.2. For example, the maximum length listed in Table 504.3.2 for a 4-inch (102 mm) connector is 6 feet (1829 mm). With a connector length greater than 6 feet (1829 mm) but not exceeding 12 feet (3658 mm), the maximum capacity must be reduced by 10 percent (0.90 × maximum vent connector capacity). With a connector length greater than 12 feet (3658 mm) but not exceeding 18 feet (5486 mm), the maximum capacity must be reduced by 20 percent (0.80 × maximum vent capacity).
2. For a connector serving a fan-assisted appliance, the minimum capacity (FAN Min) of the connector shall be determined by referring to the corresponding single appliance table. For Type B double-wall connectors, Table 504.2(1) shall be used. For single-wall connectors, Table 504.2(2) shall be used. The height (*H*) and lateral (*L*) shall be measured according to the procedures for a single-appliance vent, as if the other appliances were not present.

**TABLE 504.3.2  
MAXIMUM VENT CONNECTOR LENGTH**

CONNECTOR DIAMETER MAXIMUM (inches)	CONNECTOR HORIZONTAL LENGTH (feet)
3	4½
4	6
5	7½
6	9
7	10½
8	12
9	13½
10	15
12	18
14	21
16	24
18	27
20	30
22	33
24	36

For SI: 1 inch = 25.4 mm, 1 foot = 304.8 mm.

**504.3.4 Vent connector manifold.** Where the vent connectors are combined prior to entering the vertical portion of the common vent to form a common vent manifold, the size of the common vent manifold and the common vent shall be determined by applying a 10-percent reduction ( $0.90 \times$  maximum common vent capacity) to the common vent capacity part of the common vent tables. The length of the common vent connector manifold ( $L_m$ ) shall not exceed  $1\frac{1}{2}$  feet for each inch (457 mm per mm) of common vent connector manifold diameter ( $D$ ) (see Figure B-11).

**504.3.5 Common vertical vent offset.** Where the common vertical vent is offset, the maximum capacity of the common vent shall be reduced in accordance with Section 504.3.6. The horizontal length of the common vent offset ( $L_o$ ) shall not exceed  $1\frac{1}{2}$  feet for each inch (457 mm per mm) of common vent diameter.

**504.3.6 Elbows in vents.** For each elbow up to and including 45 degrees (0.79 rad) in the common vent, the maximum common vent capacity listed in the venting tables shall be reduced by 5 percent. For each elbow greater than 45 degrees (0.79 rad) up to and including 90 degrees (1.57 rad), the maximum common vent capacity listed in the venting tables shall be reduced by 10 percent.

**504.3.7 Elbows in connectors.** The vent connector capacities listed in the common vent sizing tables include allowance for two 90-degree (1.57 rad) elbows. For each additional elbow up to and including 45 degrees (0.79 rad), the maximum vent connector capacity listed in the venting tables shall be reduced by 5 percent. For each elbow greater than 45 degrees (0.79 rad) up to and including 90 degrees (1.57 rad), the maximum vent connector capacity listed in the venting tables shall be reduced by 10 percent.

**504.3.8 Common vent minimum size.** The cross-sectional area of the common vent shall be equal to or greater than the cross-sectional area of the largest connector.

**504.3.9 Common vent fittings.** At the point where tee or wye fittings connect to a common vent, the opening size of the fitting shall be equal to the size of the common vent. Such fittings shall not be prohibited from having reduced-size openings at the point of connection of appliance vent connectors.

**504.3.9.1 Tee and wye fittings.** Tee and wye fittings connected to a common vent shall be considered as part of the common vent and shall be constructed of materials consistent with that of the common vent.

**504.3.10 High-altitude installations.** Sea-level input ratings shall be used when determining maximum capacity for high-altitude installation. Actual input (derated for altitude) shall be used for determining minimum capacity for high-altitude installation.

**504.3.11 Connector rise measurement.** Connector rise ( $R$ ) for each appliance connector shall be measured from the draft hood outlet or flue collar to the centerline where the vent gas streams come together.

**504.3.12 Vent height measurement.** For multiple appliances all located on one floor, available total height ( $H$ ) shall

be measured from the highest draft hood outlet or flue collar up to the level of the outlet of the common vent.

**504.3.13 Multistory height measurement.** For multistory installations, available total height ( $H$ ) for each segment of the system shall be the vertical distance between the highest draft hood outlet or flue collar entering that segment and the centerline of the next higher interconnection tee (see Figure B-13).

**504.3.14 Multistory lowest portion sizing.** The size of the lowest connector and of the vertical vent leading to the lowest interconnection of a multistory system shall be in accordance with Table 504.2(1) or 504.2(2) for available total height ( $H$ ) up to the lowest interconnection (see Figure B-14).

**504.3.15 Multistory common vents.** Where used in multistory systems, vertical common vents shall be Type B double wall and shall be installed with a listed vent cap.

**504.3.16 Multistory common vent offsets.** Offsets in multistory common vent systems shall be limited to a single offset in each system, and systems with an offset shall comply with all of the following:

1. The offset angle shall not exceed 45 degrees (0.79 rad) from vertical.
2. The horizontal length of the offset shall not exceed  $1\frac{1}{2}$  feet for each inch (457 mm per mm) of common vent diameter of the segment in which the offset is located.
3. For the segment of the common vertical vent containing the offset, the common vent capacity listed in the common venting tables shall be reduced by 20 percent ( $0.80 \times$  maximum common vent capacity).
4. A multistory common vent shall not be reduced in size above the offset.

**504.3.17 Vertical vent maximum size.** Where two or more appliances are connected to a vertical vent or chimney, the flow area of the largest section of vertical vent or chimney shall not exceed seven times the smallest listed appliance categorized vent areas, flue collar area, or draft hood outlet area unless designed in accordance with approved engineering methods.

**504.3.18 Multiple input rate appliances.** For appliances with more than one input rate, the minimum vent connector capacity (FAN Min) determined from the tables shall be less than the lowest appliance input rating, and the maximum vent connector capacity (FAN Max or NAT Max) determined from the tables shall be greater than the highest appliance input rating.

**504.3.19 Liner system sizing and connections.** Listed, corrugated metallic chimney liner systems in masonry chimneys shall be sized by using Table 504.3(1) or 504.3(2) for Type B vents, with the maximum capacity reduced by 20 percent ( $0.80 \times$  maximum capacity) and the minimum capacity as shown in Table 504.3(1) or 504.3(2). Corrugated metallic liner systems installed with bends or offsets shall have their maximum capacity further reduced in accordance with Sections 504.3.5 and 504.3.6. The 20-percent

reduction for corrugated metallic chimney liner systems includes an allowance for one long-radius 90-degree (1.57 rad) turn at the bottom of the liner. Where double-wall connectors are required, tee and wye fittings used to connect to the common vent chimney liner shall be listed double-wall fittings. Connections between chimney liners and listed double-wall fittings shall be made with listed adapter fittings designed for such purpose.

**504.3.20 Chimney and vent location.** Tables 504.3(1), 504.3(2), 504.3(3), 504.3(4) and 504.3(5) shall only be used for chimneys and vents not exposed to the outdoors below the roof line. A Type B vent or listed chimney lining system passing through an unused masonry chimney flue shall not be considered to be exposed to the outdoors. A Type B vent shall not be considered to be exposed to the outdoors where it passes through an unventilated enclosure or chase insulated to a value of not less than R8.

Tables 504.3(6) and 504.3(7) shall be used for clay-tile-lined exterior masonry chimneys, provided all of the following conditions are met:

1. Vent connector is Type B double wall.
2. At least one appliance is draft hood equipped.
3. The combined appliance input rating is less than the maximum capacity given by Table 504.3(6a) for NAT+NAT or Table 504.3(7a) for FAN+NAT.
4. The input rating of each space-heating appliance is greater than the minimum input rating given by Table 504.3(6b) for NAT+NAT or Table 504.3(7b) for FAN+NAT.
5. The vent connector sizing is in accordance with Table 504.3(3).

Where these conditions cannot be met, an alternative venting design shall be used, such as a listed chimney lining system.

**Exception:** Vents serving listed appliances installed in accordance with the appliance manufacturer's installation instructions.

**504.3.21 Connector maximum and minimum size.** Vent connectors shall not be increased in size more than two sizes greater than the listed appliance categorized vent diameter, flue collar diameter or draft hood outlet diameter. Vent connectors for draft hood-equipped appliances shall not be smaller than the draft hood outlet diameter. Where a vent connector size(s) determined from the tables for a fan-assisted appliance(s) is smaller than the flue collar diameter, the use of the smaller size(s) shall be permitted provided that the installation complies with all of the following conditions:

1. Vent connectors for fan-assisted appliance flue collars 12 inches (305 mm) in diameter or smaller are not reduced by more than one table size [e.g., 12 inches to 10 inches (305 mm to 254 mm) is a one-size reduction] and those larger than 12 inches (305 mm) in diameter are not reduced more than two table sizes [e.g., 24 inches to 20 inches (610 mm to 508 mm) is a two-size reduction].

2. The fan-assisted appliance(s) is common vented with a draft-hood-equipped appliances(s).
3. The vent connector has a smooth interior wall.

**504.3.22 Component commingling.** All combinations of pipe sizes, single-wall and double-wall metal pipe shall be allowed within any connector run(s) or within the common vent, provided that all of the appropriate tables permit all of the desired sizes and types of pipe, as if they were used for the entire length of the subject connector or vent. Where single-wall and Type B double-wall metal pipes are used for vent connectors within the same venting system, the common vent must be sized using Table 504.3(2) or 504.3(4), as appropriate.

**504.3.23 Draft hood conversion accessories.** Draft hood conversion accessories for use with masonry chimneys venting listed Category I fan-assisted appliances shall be listed and installed in accordance with the manufacturer's installation instructions for such listed accessories.

**504.3.24 Multiple sizes permitted.** Where a table permits more than one diameter of pipe to be used for a connector or vent, all the permitted sizes shall be permitted to be used.

**504.3.25 Table interpolation.** Interpolation shall be permitted in calculating capacities for vent dimensions that fall between table entries (see Appendix B, Example 3).

**504.3.26 Extrapolation prohibited.** Extrapolation beyond the table entries shall not be permitted.

**504.3.27 Engineering calculations.** For vent heights less than 6 feet (1829 mm) and greater than shown in the tables, engineering methods shall be used to calculate vent capacities.

## SECTION 505 (IFGC) DIRECT-VENT, INTEGRAL VENT, MECHANICAL VENT AND VENTILATION/EXHAUST HOOD VENTING

**505.1 General.** The installation of direct-vent and integral vent appliances shall be in accordance with Section 503. Mechanical venting systems and exhaust hood venting systems shall be designed and installed in accordance with Section 503.

**505.1.1 Commercial cooking appliances vented by exhaust hoods.** Where commercial cooking appliances are vented by means of the Type I or II kitchen exhaust hood system that serves such appliances, the exhaust system shall be fan powered and the appliances shall be interlocked with the exhaust hood system to prevent appliance operation when the exhaust hood system is not operating. Where a solenoid valve is installed in the gas piping as part of an interlock system, gas piping shall not be installed to bypass such valve. Dampers shall not be installed in the exhaust system.

**Exception:** An interlock between the cooking appliance(s) and the exhaust hood system shall not be required where heat sensors or other approved methods automatically activate the exhaust hood system when cooking operations occur.

**SECTION 506 (IFGC)  
FACTORY-BUILT CHIMNEYS**

**506.1 Building heating appliances.** Factory-built chimneys for building heating appliances producing flue gases having a temperature not greater than 1,000°F (538°C), measured at the entrance to the chimney, shall be listed and labeled in accordance with UL 103 and shall be installed and terminated in accordance with the manufacturer's installation instructions.

**506.2 Support.** Where factory-built chimneys are supported by structural members, such as joists and rafters, such members shall be designed to support the additional load.

**506.3 Medium-heat appliances.** Factory-built chimneys for medium-heat appliances producing flue gases having a temperature above 1,000°F (538°C), measured at the entrance to the chimney, shall be listed and labeled in accordance with UL 959 and shall be installed and terminated in accordance with the manufacturer's installation instructions.

CHIMNEYS AND VENTS

TABLE 504.3(1)  
TYPE B DOUBLE-WALL VENT

Number of Appliances	Two or more
Appliance Type	Category I
Appliance Vent Connection	Type B double-wall connector

VENT CONNECTOR CAPACITY

VENT HEIGHT (H) (feet)	CONNECTOR RISE (R) (feet)	TYPE B DOUBLE-WALL VENT AND CONNECTOR DIAMETER—(D) inches																											
		3			4			5			6			7			8			9			10						
		APPLIANCE INPUT RATING LIMITS IN THOUSANDS OF BTU/H																											
		FAN		NAT		FAN		NAT		FAN		NAT		FAN		NAT		FAN		NAT		FAN		NAT		FAN		NAT	
Min	Max	Max	Min	Max	Max	Min	Max	Max	Min	Max	Max	Min	Max	Max	Min	Max	Max	Min	Max	Max	Min	Max	Max	Min	Max	Max	Min	Max	Max
6	1	22	37	26	35	66	46	46	106	72	58	164	104	77	225	142	92	296	185	109	376	237	128	466	289				
	2	23	41	31	37	75	55	48	121	86	60	183	124	79	253	168	95	333	220	112	424	282	131	526	345				
	3	24	44	35	38	81	62	49	132	96	62	199	139	82	275	189	97	363	248	114	463	317	134	575	386				
8	1	22	40	27	35	72	48	49	114	76	64	176	109	84	243	148	100	320	194	118	408	248	138	507	303				
	2	23	44	32	36	80	57	51	128	90	66	195	129	86	269	175	103	356	230	121	454	294	141	564	358				
	3	24	47	36	37	87	64	53	139	101	67	210	145	88	290	198	105	384	258	123	492	330	143	612	402				
10	1	22	43	28	34	78	50	49	123	78	65	189	113	89	257	154	106	341	200	125	436	257	146	542	314				
	2	23	47	33	36	86	59	51	136	93	67	206	134	91	282	182	109	374	238	128	479	305	149	596	372				
	3	24	50	37	37	92	67	52	146	104	69	220	150	94	303	205	111	402	268	131	515	342	152	642	417				
15	1	21	50	30	33	89	53	47	142	83	64	220	120	88	298	163	110	389	214	134	493	273	162	609	333				
	2	22	53	35	35	96	63	49	153	99	66	235	142	91	320	193	112	419	253	137	532	323	165	658	394				
	3	24	55	40	36	102	71	51	163	111	68	248	160	93	339	218	115	445	286	140	565	365	167	700	444				
20	1	21	54	31	33	99	56	46	157	87	62	246	125	86	334	171	107	436	224	131	552	285	158	681	347				
	2	22	57	37	34	105	66	48	167	104	64	259	149	89	354	202	110	463	265	134	587	339	161	725	414				
	3	23	60	42	35	110	74	50	176	116	66	271	168	91	371	228	113	486	300	137	618	383	164	764	466				
30	1	20	62	33	31	113	59	45	181	93	60	288	134	83	391	182	103	512	238	125	649	305	151	802	372				
	2	21	64	39	33	118	70	47	190	110	62	299	158	85	408	215	105	535	282	129	679	360	155	840	439				
	3	22	66	44	34	123	79	48	198	124	64	309	178	88	423	242	108	555	317	132	706	405	158	874	494				
50	1	19	71	36	30	133	64	43	216	101	57	349	145	78	477	197	97	627	257	120	797	330	144	984	403				
	2	21	73	43	32	137	76	45	223	119	59	358	172	81	490	234	100	645	306	123	820	392	148	1,014	478				
	3	22	75	48	33	141	86	46	229	134	61	366	194	83	502	263	103	661	343	126	842	441	151	1,043	538				
100	1	18	82	37	28	158	66	40	262	104	53	442	150	73	611	204	91	810	266	112	1,038	341	135	1,285	417				
	2	19	83	44	30	161	79	42	267	123	55	447	178	75	619	242	94	822	316	115	1,054	405	139	1,306	494				
	3	20	84	50	31	163	89	44	272	138	57	452	109	78	627	272	97	834	355	118	1,069	455	142	1,327	555				

COMMON VENT CAPACITY

VENT HEIGHT (H) (feet)	TYPE B DOUBLE-WALL COMMON VENT DIAMETER (D)—inches																				
	4			5			6			7			8			9			10		
	COMBINED APPLIANCE INPUT RATING IN THOUSANDS OF BTU/H																				
	FAN +FAN	FAN +NAT	NAT +NAT	FAN +FAN	FAN +NAT	NAT +NAT	FAN +FAN	FAN +NAT	NAT +NAT	FAN +FAN	FAN +NAT	NAT +NAT	FAN +FAN	FAN +NAT	NAT +NAT	FAN +FAN	FAN +NAT	NAT +NAT	FAN +FAN	FAN +NAT	NAT +NAT
6	92	81	65	140	116	103	204	161	147	309	248	200	404	314	260	547	434	335	672	520	410
8	101	90	73	155	129	114	224	178	163	339	275	223	444	348	290	602	480	378	740	577	465
10	110	97	79	169	141	124	243	194	178	367	299	242	477	377	315	649	522	405	800	627	495
15	125	112	91	195	164	144	283	228	206	427	352	280	556	444	365	753	612	465	924	733	565
20	136	123	102	215	183	160	314	255	229	475	394	310	621	499	405	842	688	523	1,035	826	640
30	152	138	118	244	210	185	361	297	266	547	459	360	720	585	470	979	808	605	1,209	975	740
50	167	153	134	279	244	214	421	353	310	641	547	423	854	706	550	1,164	977	705	1,451	1,188	860
100	175	163	NA	311	277	NA	489	421	NA	751	658	479	1,025	873	625	1,408	1,215	800	1,784	1,502	975

(continued)



CHIMNEYS AND VENTS

TABLE 504.3(2)  
TYPE B DOUBLE-WALL VENT

Number of Appliances	Two or more
Appliance Type	Category I
Appliance Vent Connection	Single-wall metal connector

VENT CONNECTOR CAPACITY

VENT HEIGHT (H) (feet)	CONNECTOR RISE (R) (feet)	SINGLE-WALL METAL VENT CONNECTOR DIAMETER—(D) inches																							
		3			4			5			6			7			8			9			10		
		APPLIANCE INPUT RATING LIMITS IN THOUSANDS OF BTU/H																							
		FAN		NAT		FAN		NAT		FAN		NAT		FAN		NAT		FAN		NAT		FAN		NAT	
Min	Max	Max	Min	Max	Max	Min	Max	Max	Min	Max	Max	Min	Max	Max	Min	Max	Max	Min	Max	Max	Min	Max	Max		
6	1	NA	NA	26	NA	NA	46	NA	NA	71	NA	NA	102	207	223	140	262	293	183	325	373	234	447	463	286
	2	NA	NA	31	NA	NA	55	NA	NA	85	168	182	123	215	251	167	271	331	219	334	422	281	458	524	344
	3	NA	NA	34	NA	NA	62	121	131	95	175	198	138	222	273	188	279	361	247	344	462	316	468	574	385
8	1	NA	NA	27	NA	NA	48	NA	NA	75	NA	NA	106	226	240	145	285	316	191	352	403	244	481	502	299
	2	NA	NA	32	NA	NA	57	125	126	89	184	193	127	234	266	173	293	353	228	360	450	292	492	560	355
	3	NA	NA	35	NA	NA	64	130	138	100	191	208	144	241	287	197	302	381	256	370	489	328	501	609	400
10	1	NA	NA	28	NA	NA	50	119	121	77	182	186	110	240	253	150	302	335	196	372	429	252	506	534	308
	2	NA	NA	33	84	85	59	124	134	91	189	203	132	248	278	183	311	369	235	381	473	302	517	589	368
	3	NA	NA	36	89	91	67	129	144	102	197	217	148	257	299	203	320	398	265	391	511	339	528	637	413
15	1	NA	NA	29	79	87	52	116	138	81	177	214	116	238	291	158	312	380	208	397	482	266	556	596	324
	2	NA	NA	34	83	94	62	121	150	97	185	230	138	246	314	189	321	411	248	407	522	317	568	646	387
	3	NA	NA	39	87	100	70	127	160	109	193	243	157	255	333	215	331	438	281	418	557	360	579	690	437
20	1	49	56	30	78	97	54	115	152	84	175	238	120	233	325	165	306	425	217	390	538	276	546	664	336
	2	52	59	36	82	103	64	120	163	101	182	252	144	243	346	197	317	453	259	400	574	331	558	709	403
	3	55	62	40	87	107	72	125	172	113	190	264	164	252	363	223	326	476	294	412	607	375	570	750	457
30	1	47	60	31	77	110	57	112	175	89	169	278	129	226	380	175	296	497	230	378	630	294	528	779	358
	2	51	62	37	81	115	67	117	185	106	177	290	152	236	397	208	307	521	274	389	662	349	541	819	425
	3	54	64	42	85	119	76	122	193	120	185	300	172	244	412	235	316	542	309	400	690	394	555	855	482
50	1	46	69	34	75	128	60	109	207	96	162	336	137	217	460	188	284	604	245	364	768	314	507	951	384
	2	49	71	40	79	132	72	114	215	113	170	345	164	226	473	223	294	623	293	376	793	375	520	983	458
	3	52	72	45	83	136	82	119	221	123	178	353	186	235	486	252	304	640	331	387	816	423	535	1,013	518
100	1	45	79	34	71	150	61	104	249	98	153	424	140	205	585	192	269	774	249	345	993	321	476	1,236	393
	2	48	80	41	75	153	73	110	255	115	160	428	167	212	593	228	279	788	299	358	1,011	383	490	1,259	469
	3	51	81	46	79	157	85	114	260	129	168	433	190	222	603	256	289	801	339	368	1,027	431	506	1,280	527

COMMON VENT CAPACITY

VENT HEIGHT (H) (feet)	TYPE B DOUBLE-WALL COMMON VENT DIAMETER—(D) inches																				
	4			5			6			7			8			9			10		
	COMBINED APPLIANCE INPUT RATING IN THOUSANDS OF BTU/H																				
	FAN +FAN	FAN +NAT	NAT +NAT	FAN +FAN	FAN +NAT	NAT +NAT	FAN +FAN	FAN +NAT	NAT +NAT	FAN +FAN	FAN +NAT	NAT +NAT	FAN +FAN	FAN +NAT	NAT +NAT	FAN +FAN	FAN +NAT	NAT +NAT	FAN +FAN	FAN +NAT	NAT +NAT
6	NA	78	64	NA	113	99	200	158	144	304	244	196	398	310	257	541	429	332	665	515	407
8	NA	87	71	NA	126	111	218	173	159	331	269	218	436	342	285	592	473	373	730	569	460
10	NA	94	76	163	137	120	237	189	174	357	292	236	467	369	309	638	512	398	787	617	487
15	121	108	88	189	159	140	275	221	200	416	343	274	544	434	357	738	599	456	905	718	553
20	131	118	98	208	177	156	305	247	223	463	383	302	606	487	395	824	673	512	1,013	808	626
30	145	132	113	236	202	180	350	286	257	533	446	349	703	570	459	958	790	593	1,183	952	723
50	159	145	128	268	233	208	406	337	296	622	529	410	833	686	535	1,139	954	689	1,418	1,157	838
100	166	153	NA	297	263	NA	469	398	NA	726	633	464	999	846	606	1,378	1,185	780	1,741	1,459	948

For SI: 1 inch = 25.4 mm, 1 foot = 304.8 mm, 1 British thermal unit per hour = 0.2931 W.



**TABLE 504.3(3)  
MASONRY CHIMNEY**

<b>Number of Appliances</b>	Two or more
<b>Appliance Type</b>	Category I
<b>Appliance Vent Connection</b>	Type B double-wall connector

**VENT CONNECTOR CAPACITY**

VENT HEIGHT (H) (feet)	CONNECTOR RISE (F) (feet)	TYPE B DOUBLE-WALL VENT CONNECTOR DIAMETER—(D) inches																									
		3			4			5			6			7			8			9			10				
		APPLIANCE INPUT RATING LIMITS IN THOUSANDS OF BTU/H																									
		FAN		NAT		FAN		NAT		FAN		NAT		FAN		NAT		FAN		NAT		FAN		NAT		FAN	
Min	Max	Max	Min	Max	Max	Min	Max	Max	Min	Max	Max	Min	Max	Max	Min	Max	Max	Min	Max	Max	Min	Max	Max	Min	Max	Max	
6	1	24	33	21	39	62	40	52	106	67	65	194	101	87	274	141	104	370	201	124	479	253	145	599	319		
	2	26	43	28	41	79	52	53	133	85	67	230	124	89	324	173	107	436	232	127	562	300	148	694	378		
	3	27	49	34	42	92	61	55	155	97	69	262	143	91	369	203	109	491	270	129	633	349	151	795	439		
8	1	24	39	22	39	72	41	55	117	69	71	213	105	94	304	148	113	414	210	134	539	267	156	682	335		
	2	26	47	29	40	87	53	57	140	86	73	246	127	97	350	179	116	473	240	137	615	311	160	776	394		
	3	27	52	34	42	97	62	59	159	98	75	269	145	99	383	206	119	517	276	139	672	358	163	848	452		
10	1	24	42	22	38	80	42	55	130	71	74	232	108	101	324	153	120	444	216	142	582	277	165	739	348		
	2	26	50	29	40	93	54	57	153	87	76	261	129	103	366	184	123	498	247	145	652	321	168	825	407		
	3	27	55	35	41	105	63	58	170	100	78	284	148	106	397	209	126	540	281	147	705	366	171	893	463		
15	1	24	48	23	38	93	44	54	154	74	72	277	114	100	384	164	125	511	229	153	658	297	184	824	375		
	2	25	55	31	39	105	55	56	174	89	74	299	134	103	419	192	128	558	260	156	718	339	187	900	432		
	3	26	59	35	41	115	64	57	189	102	76	319	153	105	448	215	131	597	292	159	760	382	190	960	486		
20	1	24	52	24	37	102	46	53	172	77	71	313	119	98	437	173	123	584	239	150	752	312	180	943	397		
	2	25	58	31	39	114	56	55	190	91	73	335	138	101	467	199	126	625	270	153	805	354	184	1,011	452		
	3	26	63	35	40	123	65	57	204	104	75	353	157	104	493	222	129	661	301	156	851	396	187	1,067	505		
30	1	24	54	25	37	111	48	52	192	82	69	357	127	96	504	187	119	680	255	145	883	337	175	1,115	432		
	2	25	60	32	38	122	58	54	208	95	72	376	145	99	531	209	122	715	287	149	928	378	179	1,171	484		
	3	26	64	36	40	131	66	56	221	107	74	392	163	101	554	233	125	746	317	152	968	418	182	1,220	535		
50	1	23	51	25	36	116	51	51	209	89	67	405	143	92	582	213	115	798	294	140	1,049	392	168	1,334	506		
	2	24	59	32	37	127	61	53	225	102	70	421	161	95	604	235	118	827	326	143	1,085	433	172	1,379	558		
	3	26	64	36	39	135	69	55	237	115	72	435	180	98	624	260	121	854	357	147	1,118	474	176	1,421	611		
100	1	23	46	24	35	108	50	49	208	92	65	428	155	88	640	237	109	907	334	134	1,222	454	161	1,589	596		
	2	24	53	31	37	120	60	51	224	105	67	444	174	92	660	260	113	933	368	138	1,253	497	165	1,626	651		
	3	25	59	35	38	130	68	53	237	118	69	458	193	94	679	285	116	956	399	141	1,282	540	169	1,661	705		

**COMMON VENT CAPACITY**

VENT HEIGHT (H) (feet)	MINIMUM INTERNAL AREA OF MASONRY CHIMNEY FLUE (square inches)																							
	12			19			28			38			50			63			78			113		
	COMBINED APPLIANCE INPUT RATING IN THOUSANDS OF BTU/H																							
	+FAN	+FAN	+NAT	+FAN	+FAN	+NAT	+FAN	+FAN	+NAT	+FAN	+FAN	+NAT	+FAN	+FAN	+NAT	+FAN	+FAN	+NAT	+FAN	+FAN	+NAT	+FAN	+FAN	+NAT
6	NA	74	25	NA	119	46	NA	178	71	NA	257	103	NA	351	143	NA	458	188	NA	582	246	1,041	853	NA
8	NA	80	28	NA	130	53	NA	193	82	NA	279	119	NA	384	163	NA	501	218	724	636	278	1,144	937	408
10	NA	84	31	NA	138	56	NA	207	90	NA	299	131	NA	409	177	606	538	236	776	686	302	1,226	1,010	454
15	NA	NA	36	NA	152	67	NA	233	106	NA	334	152	523	467	212	682	611	283	874	781	365	1,374	1,156	546
20	NA	NA	41	NA	NA	75	NA	250	122	NA	368	172	565	508	243	742	668	325	955	858	419	1,513	1,286	648
30	NA	NA	NA	NA	NA	NA	NA	270	137	NA	404	198	615	564	278	816	747	381	1,062	969	496	1,702	1,473	749
50	NA	NA	NA	NA	NA	NA	NA	NA	NA	NA	NA	NA	NA	620	328	879	831	461	1,165	1,089	606	1,905	1,692	922
100	NA	NA	NA	NA	NA	NA	NA	NA	NA	NA	NA	NA	NA	NA	348	NA	NA	499	NA	NA	669	2,053	1,921	1,058

For SI: 1 inch = 25.4 mm, 1 square inch = 645.16 mm<sup>2</sup>, 1 foot = 304.8 mm, 1 British thermal unit per hour = 0.2931 W.

**CHIMNEYS AND VENTS**

**TABLE 504.3(4)  
MASONRY CHIMNEY**

<b>Number of Appliances</b>	Two or more
<b>Appliance Type</b>	Category I
<b>Appliance Vent Connection</b>	Single-wall metal connector

**VENT CONNECTOR CAPACITY**

VENT HEIGHT (H) (feet)	CONNECTOR RISE (R) (feet)	SINGLE-WALL METAL VENT CONNECTOR DIAMETER (D)—inches																											
		3		4			5			6			7			8			9			10							
		APPLIANCE INPUT RATING LIMITS IN THOUSANDS OF BTU/H																											
		FAN		NAT		FAN		NAT		FAN		NAT		FAN		NAT		FAN		NAT		FAN		NAT		FAN		NAT	
Min	Max	Max	Min	Max	Max	Min	Max	Max	Min	Max	Max	Min	Max	Max	Min	Max	Max	Min	Max	Max	Min	Max	Max	Min	Max	Max	Min	Max	Max
6	1	NA	NA	21	NA	NA	39	NA	NA	66	179	191	100	231	271	140	292	366	200	362	474	252	499	594	316				
	2	NA	NA	28	NA	NA	52	NA	NA	84	186	227	123	239	321	172	301	432	231	373	557	299	509	696	376				
	3	NA	NA	34	NA	NA	61	134	153	97	193	258	142	247	365	202	309	491	269	381	634	348	519	793	437				
8	1	NA	NA	21	NA	NA	40	NA	NA	68	195	208	103	250	298	146	313	407	207	387	530	263	529	672	331				
	2	NA	NA	28	NA	NA	52	137	139	85	202	240	125	258	343	177	323	465	238	397	607	309	540	766	391				
	3	NA	NA	34	NA	NA	62	143	156	98	210	264	145	266	376	205	332	509	274	407	663	356	551	838	450				
10	1	NA	NA	22	NA	NA	41	130	151	70	202	225	106	267	316	151	333	434	213	410	571	273	558	727	343				
	2	NA	NA	29	NA	NA	53	136	150	86	210	255	128	276	358	181	343	489	244	420	640	317	569	813	403				
	3	NA	NA	34	97	102	62	143	166	99	217	277	147	284	389	207	352	530	279	430	694	363	580	880	459				
15	1	NA	NA	23	NA	NA	43	129	151	73	199	271	112	268	376	161	349	502	225	445	646	291	623	808	366				
	2	NA	NA	30	92	103	54	135	170	88	207	295	132	277	411	189	359	548	256	456	706	334	634	884	424				
	3	NA	NA	34	96	112	63	141	185	101	215	315	151	286	439	213	368	586	289	466	755	378	646	945	479				
20	1	NA	NA	23	87	99	45	128	167	76	197	303	117	265	425	169	345	569	235	439	734	306	614	921	347				
	2	NA	NA	30	91	111	55	134	185	90	205	325	136	274	455	195	355	610	266	450	787	348	627	986	443				
	3	NA	NA	35	96	119	64	140	199	103	213	343	154	282	481	219	365	644	298	461	831	391	639	1,042	496				
30	1	NA	NA	24	86	108	47	126	187	80	193	347	124	259	492	183	338	665	250	430	864	330	600	1,089	421				
	2	NA	NA	31	91	119	57	132	203	93	201	366	142	269	518	205	348	699	282	442	908	372	613	1,145	473				
	3	NA	NA	35	95	127	65	138	216	105	209	381	160	277	540	229	358	729	312	452	946	412	626	1,193	524				
50	1	NA	NA	24	85	113	50	124	204	87	188	392	139	252	567	208	328	778	287	417	1,022	383	582	1,302	492				
	2	NA	NA	31	89	123	60	130	218	100	196	408	158	262	588	230	339	806	320	429	1,058	425	596	1,346	545				
	3	NA	NA	35	94	131	68	136	231	112	205	422	176	271	607	255	349	831	351	440	1,090	466	610	1,386	597				
100	1	NA	NA	23	84	104	49	122	200	89	182	410	151	243	617	232	315	875	328	402	1,181	444	560	1,537	580				
	2	NA	NA	30	88	115	59	127	215	102	190	425	169	253	636	254	326	899	361	415	1,210	488	575	1,570	634				
	3	NA	NA	34	93	124	67	133	228	115	199	438	188	262	654	279	337	921	392	427	1,238	529	589	1,604	687				

**COMMON VENT CAPACITY**

VENT HEIGHT (H) (feet)	MINIMUM INTERNAL AREA OF MASONRY CHIMNEY FLUE (square inches)																									
	12		19			28			38			50			63			78			113					
	COMBINED APPLIANCE INPUT RATING IN THOUSANDS OF BTU/H																									
	FAN +FAN	FAN +NAT	NAT +NAT	FAN +FAN	FAN +NAT	NAT +NAT	FAN +FAN	FAN +NAT	NAT +NAT	FAN +FAN	FAN +NAT	NAT +NAT	FAN +FAN	FAN +NAT	NAT +NAT	FAN +FAN	FAN +NAT	NAT +NAT	FAN +FAN	FAN +NAT	NAT +NAT	FAN +FAN	FAN +NAT	NAT +NAT	FAN +FAN	FAN +NAT
6	NA	NA	25	NA	118	45	NA	176	71	NA	255	102	NA	348	142	NA	455	187	NA	579	245	NA	846	NA		
8	NA	NA	28	NA	128	52	NA	190	81	NA	276	118	NA	380	162	NA	497	217	NA	633	277	1,136	928	405		
10	NA	NA	31	NA	136	56	NA	205	89	NA	295	129	NA	405	175	NA	532	234	171	680	300	1,216	1,000	450		
15	NA	NA	36	NA	NA	66	NA	230	105	NA	335	150	NA	400	210	677	602	280	866	772	360	1,359	1,139	540		
20	NA	NA	NA	NA	NA	74	NA	247	120	NA	362	170	NA	503	240	765	661	321	947	849	415	1,495	1,264	640		
30	NA	NA	NA	NA	NA	NA	NA	NA	135	NA	398	195	NA	558	275	808	739	377	1,052	957	490	1,682	1,447	740		
50	NA	NA	NA	NA	NA	NA	NA	NA	NA	NA	NA	NA	NA	612	325	NA	821	456	1,152	1,076	600	1,879	1,672	910		
100	NA	NA	NA	NA	NA	NA	NA	NA	NA	NA	NA	NA	NA	NA	NA	NA	NA	494	NA	NA	663	2,006	1,885	1,046		

For SI: 1 inch = 25.4 mm, 1 square inch = 645.16 mm<sup>2</sup>, 1 foot = 304.8 mm, 1 British thermal unit per hour = 0.2931 W.

**TABLE 504.3(5)  
SINGLE-WALL METAL PIPE OR TYPE ASBESTOS CEMENT VENT**

<b>Number of Appliances</b>	Two or more
<b>Appliance Type</b>	Draft hood-equipped
<b>Appliance Vent Connection</b>	Direct to pipe or vent

**VENT CONNECTOR CAPACITY**

TOTAL VENT HEIGHT (H) (feet)	CONNECTOR RISE (R) (feet)	VENT CONNECTOR DIAMETER—(D) inches					
		3	4	5	6	7	8
		MAXIMUM APPLIANCE INPUT RATING IN THOUSANDS OF BTU/H					
6-8	1	21	40	68	102	146	205
	2	28	53	86	124	178	235
	3	34	61	98	147	204	275
15	1	23	44	77	117	179	240
	2	30	56	92	134	194	265
	3	35	64	102	155	216	298
30 and up	1	25	49	84	129	190	270
	2	31	58	97	145	211	295
	3	36	68	107	164	232	321

**COMMON VENT CAPACITY**

TOTAL VENT HEIGHT (H) (feet)	COMMON VENT DIAMETER—(D) inches						
	4	5	6	7	8	10	12
	COMBINED APPLIANCE INPUT RATING IN THOUSANDS OF BTU/H						
6	48	78	111	155	205	320	NA
8	55	89	128	175	234	365	505
10	59	95	136	190	250	395	560
15	71	115	168	228	305	480	690
20	80	129	186	260	340	550	790
30	NA	147	215	300	400	650	940
50	NA	NA	NA	360	490	810	1,190

For SI: 1 inch = 25.4 mm, 1 foot = 304.8 mm, 1 British thermal unit per hour = 0.2931 W.

**CHIMNEYS AND VENTS**

**TABLE 504.3(6a)  
EXTERIOR MASONRY CHIMNEY**

<b>Number of Appliances</b>	Two or more
<b>Appliance Type</b>	NAT + NAT
<b>Appliance Vent Connection</b>	Type B double-wall connector

**Combined Appliance Maximum  
Input Rating in Thousands of Btu per Hour**

VENT HEIGHT (feet)	INTERNAL AREA OF CHIMNEY (square inches)							
	12	19	28	38	50	63	78	113
6	25	46	71	103	143	188	246	NA
8	28	53	82	119	163	218	278	408
10	31	56	90	131	177	236	302	454
15	NA	67	106	152	212	283	365	546
20	NA	NA	NA	NA	NA	325	419	648
30	NA	NA	NA	NA	NA	NA	496	749
50	NA	NA	NA	NA	NA	NA	NA	922
100	NA	NA	NA	NA	NA	NA	NA	NA

**TABLE 504.3(6b)  
EXTERIOR MASONRY CHIMNEY**

<b>Number of Appliances</b>	Two or more
<b>Appliance Type</b>	NAT + NAT
<b>Appliance Vent Connection</b>	Type B double-wall connector

**Minimum Allowable Input Rating of  
Space-Heating Appliance in Thousands of Btu per Hour**

VENT HEIGHT (feet)	INTERNAL AREA OF CHIMNEY (square inches)							
	12	19	28	38	50	63	78	113
<b>37°F or Greater Local 99% Winter Design Temperature: 37°F or Greater</b>								
6	0	0	0	0	0	0	0	NA
8	0	0	0	0	0	0	0	0
10	0	0	0	0	0	0	0	0
15	NA	0	0	0	0	0	0	0
20	NA	NA	NA	NA	NA	184	0	0
30	NA	NA	NA	NA	NA	393	334	0
50	NA	NA	NA	NA	NA	NA	NA	579
100	NA	NA	NA	NA	NA	NA	NA	NA
<b>27 to 36°F Local 99% Winter Design Temperature: 27 to 36°F</b>								
6	0	0	68	NA	NA	180	212	NA
8	0	0	82	NA	NA	187	214	263
10	0	51	NA	NA	NA	201	225	265
15	NA	NA	NA	NA	NA	253	274	305
20	NA	NA	NA	NA	NA	307	330	362
30	NA	NA	NA	NA	NA	NA	445	485
50	NA	NA	NA	NA	NA	NA	NA	763
100	NA	NA	NA	NA	NA	NA	NA	NA

**TABLE 504.3(6b)  
EXTERIOR MASONRY CHIMNEY—continued**

**Minimum Allowable Input Rating of  
Space-Heating Appliance in Thousands of Btu per Hour**

VENT HEIGHT (feet)	INTERNAL AREA OF CHIMNEY (square inches)							
	12	19	28	38	50	63	78	113
<b>17 to 26°F Local 99% Winter Design Temperature: 17 to 26°F</b>								
6	NA	NA	NA	NA	NA	NA	NA	NA
8	NA	NA	NA	NA	NA	NA	264	352
10	NA	NA	NA	NA	NA	NA	278	358
15	NA	NA	NA	NA	NA	NA	331	398
20	NA	NA	NA	NA	NA	NA	387	457
30	NA	NA	NA	NA	NA	NA	NA	581
50	NA	NA	NA	NA	NA	NA	NA	862
100	NA	NA	NA	NA	NA	NA	NA	NA
<b>5 to 16°F Local 99% Winter Design Temperature: 5 to 16°F</b>								
6	NA	NA	NA	NA	NA	NA	NA	NA
8	NA	NA	NA	NA	NA	NA	NA	NA
10	NA	NA	NA	NA	NA	NA	NA	430
15	NA	NA	NA	NA	NA	NA	NA	485
20	NA	NA	NA	NA	NA	NA	NA	547
30	NA	NA	NA	NA	NA	NA	NA	682
50	NA	NA	NA	NA	NA	NA	NA	NA
100	NA	NA	NA	NA	NA	NA	NA	NA
<b>4°F or Lower Local 99% Winter Design Temperature: 4°F or Lower</b>								
<b>Not recommended for any vent configurations</b>								

Note: See Figure B-19 in Appendix B for a map showing local 99 percent winter design temperatures in the United States.

For SI: °C = [(°F - 32)/1.8], 1 inch = 25.4 mm, 1 square inch = 645.16 mm<sup>2</sup>, 1 foot = 304.8 mm, 1 British thermal unit per hour = 0.2931 W.

**TABLE 504.3(7a)  
EXTERIOR MASONRY CHIMNEY**

<b>Number of Appliances</b>	Two or more
<b>Appliance Type</b>	FAN + NAT
<b>Appliance Vent Connection</b>	Type B double-wall connector

**Combined Appliance Maximum  
Input Rating in Thousands of Btu per Hour**

VENT HEIGHT (feet)	INTERNAL AREA OF CHIMNEY (square inches)							
	12	19	28	38	50	63	78	113
6	74	119	178	257	351	458	582	853
8	80	130	193	279	384	501	636	937
10	84	138	207	299	409	538	686	1,010
15	NA	152	233	334	467	611	781	1,156
20	NA	NA	250	368	508	668	858	1,286
30	NA	NA	NA	404	564	747	969	1,473
50	NA	NA	NA	NA	NA	831	1,089	1,692
100	NA	NA	NA	NA	NA	NA	NA	1,921

**TABLE 504.3(7b)  
EXTERIOR MASONRY CHIMNEY**

<b>Number of Appliances</b>	Two or more
<b>Appliance Type</b>	FAN + NAT
<b>Appliance Vent Connection</b>	Type B double-wall connector

**Minimum Allowable Input Rating of  
Space-Heating Appliance in Thousands of Btu per Hour**

VENT HEIGHT (feet)	INTERNAL AREA OF CHIMNEY (square inches)							
	12	19	28	38	50	63	78	113
<b>37°F or Greater</b> Local 99% Winter Design Temperature: 37°F or Greater								
6	0	0	0	0	0	0	0	0
8	0	0	0	0	0	0	0	0
10	0	0	0	0	0	0	0	0
15	NA	0	0	0	0	0	0	0
20	NA	NA	123	190	249	184	0	0
30	NA	NA	NA	334	398	393	334	0
50	NA	NA	NA	NA	NA	714	707	579
100	NA	NA	NA	NA	NA	NA	NA	1,600
<b>27 to 36°F</b> Local 99% Winter Design Temperature: 27 to 36°F								
6	0	0	68	116	156	180	212	266
8	0	0	82	127	167	187	214	263
10	0	51	97	141	183	210	225	265
15	NA	111	142	183	233	253	274	305
20	NA	NA	187	230	284	307	330	362
30	NA	NA	NA	330	319	419	445	485
50	NA	NA	NA	NA	NA	672	705	763
100	NA	NA	NA	NA	NA	NA	NA	1,554

**TABLE 504.3(7b)  
EXTERIOR MASONRY CHIMNEY—continued**

**Minimum Allowable Input Rating of  
Space-Heating Appliance in Thousands of Btu per Hour**

VENT HEIGHT (feet)	INTERNAL AREA OF CHIMNEY (square inches)							
	12	19	28	38	50	63	78	113
<b>17 to 26°F</b> Local 99% Winter Design Temperature: 17 to 26°F								
6	0	55	99	141	182	215	259	349
8	52	74	111	154	197	226	264	352
10	NA	90	125	169	214	245	278	358
15	NA	NA	167	212	263	296	331	398
20	NA	NA	212	258	316	352	387	457
30	NA	NA	NA	362	429	470	507	581
50	NA	NA	NA	NA	NA	723	766	862
100	NA	NA	NA	NA	NA	NA	NA	1,669
<b>5 to 16°F</b> Local 99% Winter Design Temperature: 5 to 16°F								
6	NA	78	121	166	214	252	301	416
8	NA	94	135	182	230	269	312	423
10	NA	111	149	198	250	289	331	430
15	NA	NA	193	247	305	346	393	485
20	NA	NA	NA	293	360	408	450	547
30	NA	NA	NA	377	450	531	580	682
50	NA	NA	NA	NA	NA	797	853	972
100	NA	NA	NA	NA	NA	NA	NA	1,833
<b>-10 to 4°F</b> Local 99% Winter Design Temperature: -10 to 4°F								
6	NA	NA	145	196	249	296	349	484
8	NA	NA	159	213	269	320	371	494
10	NA	NA	175	231	292	339	397	513
15	NA	NA	NA	283	351	404	457	586
20	NA	NA	NA	333	408	468	528	650
30	NA	NA	NA	NA	NA	603	667	805
50	NA	NA	NA	NA	NA	NA	955	1,003
100	NA	NA	NA	NA	NA	NA	NA	NA
<b>-11°F or Lower</b> Local 99% Winter Design Temperature: -11°F or Lower								
<b>Not recommended for any vent configurations</b>								

Note: See Figure B-19 in Appendix B for a map showing local 99 percent winter design temperatures in the United States.

For SI: °C = [(°F - 32)/1.8, 1 inch = 25.4 mm, 1 square inch = 645.16 mm<sup>2</sup>, 1 foot = 304.8 mm, 1 British thermal unit per hour = 0.2931 W.

